

# DICHTOMATIK O-RINGS



The information contained herein is considered to be reliable, but no assurances, warrants or guarantees whatsoever, of any kind, are provided with regard to its correctness or suitability for any purpose.

The information reproduced herein is based on laboratory tests and is not necessarily indicative of the performance of the end product. Complete testing and the performance of the end product are the user's responsibility

# CONTENTS

<b>COMPANY</b>	4
Industry-specific and customized service concepts	6
Product portfolio of the Dichtomatik brand	7
<b>O-RINGS – A CLASSIC ON FUTURE COURSE</b>	8
Fields of application	9
Special applications	9
Standard dimensions	11
Tolerances/Surface deviations	11
<b>QUALITY ASSURANCE</b>	12
<b>MATERIALS</b>	14
Standard materials	15
Material certifications	16
Comparative presentation of some elastomer properties	17
<b>TERMS</b>	18
<b>INSTALLATION SPACES AND DESIGN RECOMMENDATIONS</b>	20
Static seals	21
Dynamic seals	21
Design guidelines	36
Layout guidelines	39
Installation instructions	40
Back-up rings	41



## COMPANY

The Freudenberg Group was founded in 1849 and is still owned by the approximately 300 descendants of the company founder. The resulting financial stability and social consciousness are decisive success factors that create trust. Today, Freudenberg is a global, broadly diversified Group that is divided into Business Groups that operate in a wide variety of different sectors. The company has always been considered an innovation and technology leader, from Vileda® brand household products to technically complex sealing solutions.

Freudenberg Sealing Technologies (FST) is the largest Business Group in the Freudenberg Group and part of the Seals and Vibration Control Technology Division. It is a supplier as well as a development and service partner to customers in a wide range of market segments, such as the automotive industry, civil aviation, mechanical engineering and shipbuilding, the food and pharmaceutical industry and the agricultural and construction machinery industry.

Starting with the Simmerring® developed in 1929, FST can today offer through its Freudenberg product brand a broad, continuously customer-oriented product portfolio of premium sealing technology for moderately to high demanding applications – from tailor-made individual solutions to complete sealing packages. The Freudenberg brand globally stands for uncompromising and high quality as well as state-of-the-art sealing solutions setting market benchmarks. It benefits from FST's more than 175 years of engineering and materials experience in the research, development and introduction of innovative product and process solutions.

In addition, Dichtomatik brand products are ideal for several moderately demanding applications in general industry. The wide range of products is characterized by a very good price-performance ratio. Manufactured by certified external suppliers, the sealing products and solutions reliably meet common industrial market standards. Additional services such as general technical support complement the range.

With a worldwide network of more than 400 seal suppliers for the Dichtomatik brand, Freudenberg Sealing Technologies is in a position to offer a suitable procurement alternative at any time and thus avoid supply bottlenecks and risk mitigation. With its sourcing service, FST makes life easier for its customers by offering a crisis-resistant source, reducing the administrative burden, and thus ensuring a carefree supply for industrial standard seals. Quality controls along the supply chain and a good negotiating position thanks to large purchasing volumes create an attractive overall package.

Freudenberg Sealing Technologies offers technical services such as the preparation of drawings, radial force measurements, comprehensive quality and material documentation as well as material modifications and testing to ensure that all seals function reliably even in individual applications. Furthermore, local availability ensures short distances and fast response times to best serve customer needs. Digital service offerings like the online-ordering platform EASY, online configurators and resistance tools enable self-service, speed and convenience.

## FREUDENBERG SEALING TECHNOLOGIES SERVES THE ENTIRE SEALING MARKET WITH THIS COMPLEMENTARY PRODUCT PORTFOLIO AND THUS MEETS ALL MARKET REQUIREMENTS – QUICKLY, RELIABLY AND FROM A SINGLE SOURCE

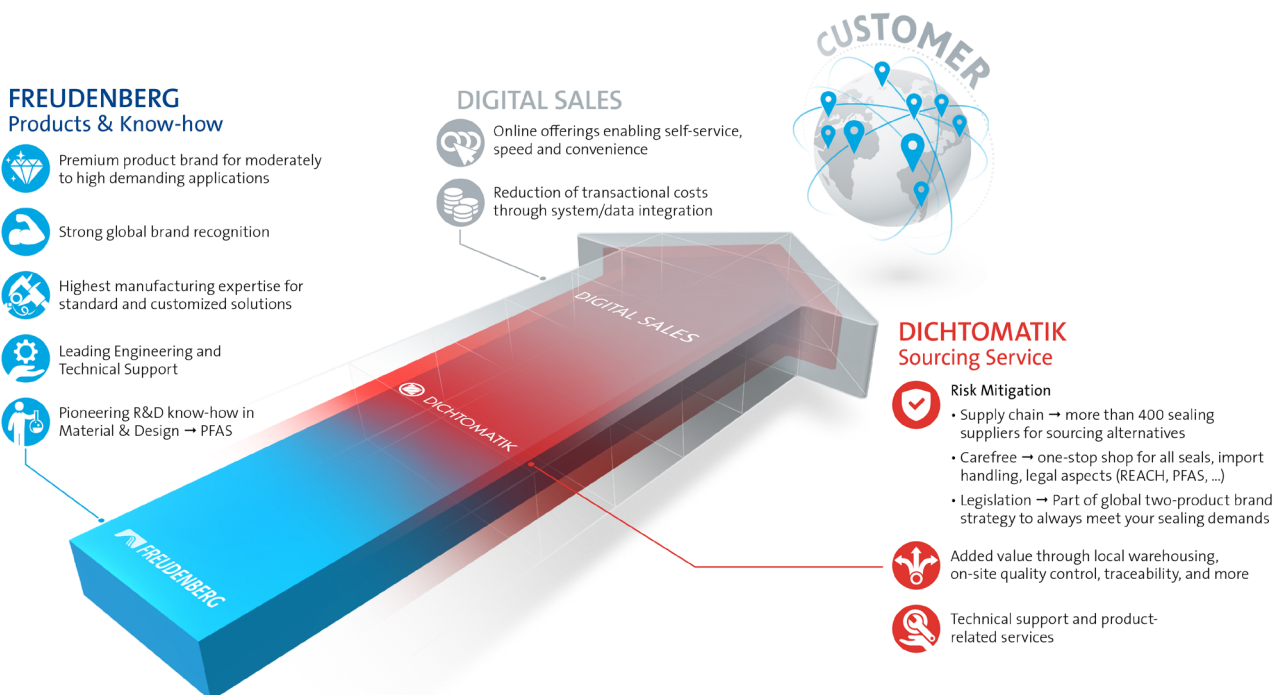

# INDUSTRY-SPECIFIC AND CUSTOMIZED SERVICE CONCEPTS

## ONLINE ORDERING PLATFORM EASY

The EASY online ordering platform enables straightforward order processing and provides real time information regarding the price, delivery time and availability of stock. The primary details for each product are displayed on a summary page where drawings of the installation space and cross-section are also available for download. The EASY Business Connector is used to transfer your orders directly to your SAP system; this ensures that you are always up to date on the status of your order. Register today if you do not yet have an EASY account.



## APPLICATION KNOW-HOW

Dichtomatik brand products are also certified for special applications. This enables us to find the right solution for every application. To ensure the safe functionality of the seals, even in individual applications, our team of specialists offer technical services such as drawing preparation, radial force measurements, comprehensive quality and material documentation as well as material modifications and testing based on their extensive technical and application expertise. Customer-specific sealing solutions, kitting and single packaging are just some of the other services that can be offered (country-specific).



## LOGISTICAL SERVICES AND QUALITY STANDARDS

The 6,500 m<sup>2</sup> warehouse in Hamburg, which functions as a European logistics hub, has just one objective - delivering the uniquely high number of Dichtomatik brand products as quickly as possible to the locations they are needed at. In addition to the roughly 60,000 standard designs, around 15,000 customer-specific seals are available from stock. Additional warehouse locations around the world support the supply chain to ensure rapid delivery to our customers..



Special logistics solutions, such as Kanban or vendor-managed inventory, quality testing and simplified customs processes due to certifications, simplify order processing. The warehouse in Hamburg is certified according to DIN ISO 9001 and DIN ISO 14001, thus guaranteeing standardized processes in the quality and environmental management system. In addition, current processes are analyzed and improved in regular Kaizen workshops. Furthermore, warehouse processes are supported by new technologies.

For example, the forklifts have been converted into mobile workstations by using tablets and portable printers, and innovative glove scanners are used for scanning processes. Our other warehouses also meet the highest quality requirements and are part of regular certifications. Our other warehouses also meet the highest quality requirements and are regularly inspected and certified by internal and external organizations.

# PRODUCT PORTFOLIO OF THE DICHTOMATIK BRAND

## PRODUCTS FOR STATIC APPLICATIONS



The whole range of static seals – O-rings, cords, x-rings, cover seals, bolt seals, flange and profile seals, etc. – are available in large number of dimensions, in both metric and imperial units, for a wide range of international standards. The variety of materials on offer leaves nothing to be desired, with a selection of materials certified for a diverse cross section of application-specific requirements.

## PRODUCTS ROTATING MOVEMENTS



Rotary shaft seals are available in standard profiles with and without protective lips and in the compounds NBR and FKM. In addition to these standard designs, the product range also includes special designs of rotary shaft seals, axial seals, shaft sleeves and radial seals for rotary and swivel movements.

## PRODUCTS FOR TRANSLATIONAL MOVEMENTS

Piston seals, rod seals, wipers, guide belts and guide rings for hydraulic applications are readily available in countless standard dimensions in the materials NBR, PTFE, TPU, hard fabric and fabric-reinforced NBR. Application-specific modifications of the design or compound can also be accommodated.

## IMPORTANT NOTE

Dichtomatik brand products meet common industrial market quality standards and are therefore suitable for moderately demanding and non-safety-critical applications. Dichtomatik products are not approved for use in the automotive industry, aerospace and other safety-critical applications. An overview of complementary premium sealing solutions can be found at [www.fst.com](http://www.fst.com).



**e-Catalog**



## O-RINGS – A CLASSIC FOR MODERN TIMES

O-rings are circumferentially closed, circular sealing elements made of elastomeric materials and are produced by way of vulcanization in molds. The O-ring achieves its sealing effect by deforming the cross section after installation and pressing in the installation space and can be

pressed radially or axially inside the installation space. In the operating condition, the media pressure strengthens the sealing function, since the elastomer material behaves like an incompressible fluid under pressure.



## FIELDS OF APPLICATION

O-rings are mainly used to seal stationary machines and system components (static application) against liquid and gaseous media, e.g. flange and cover seals, pipe fittings and the cylinder head and base in hydraulic cylinders. Under certain conditions, O-rings can also be used for reciprocating, rotating and superimposed screw movements (dynamic application). If the installation space is designed properly, they are constructed properly and the correct material is chosen, pressures up to 1,000 bar can be sealed. If necessary, back-up-rings must be used. O-rings are used in many different industries, e.g. hydraulics, vehicle construction, vacuum applications and in plant and mechanical engineering.

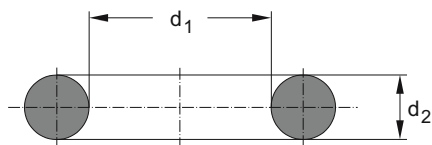

d1 inner diameter  
d2 cord thickness

## SPECIAL APPLICATIONS

- Aseptic pipe fittings to DIN 118641 Form A, standard dimensions available from stock, material FKM 75 perox. with conformity tests FDA (Food and Drug Administration), EU (VO) 1935/2004, EU (VO) 2023/2006, 3A® Sanitary Standards Class I and CIP/SIP (Cleaning In Place/ Sterilization In Place)
- Hydraulic fittings (straight screw-in and pipe connections according to AS 568, metric threads with conical countersink according to ISO 6149, EO series and SAE flanges), standard dimensions in NBR 90 and FKM 90 available from stock
- Ozone and weather-resistant O-rings in NBR 70 and 90
- Low temperature hydraulics (HNBR 75 and 90 with reference tests to John Deere factory standards)
- Gas appliances and systems with DVGW type examination certificates DIN EN 549/DIN EN682
- Food contact with reference tests FDA 21 CFR § 177.2600, EU (VO) 1935/2004
- Drinking water with DVGW type examination certificate WA/WB, ACS, BS 6920

Dichtomatik O-rings are available in EPDM, FKM, NBR, VMQ and with FEP coating (including a FKM or VMQ core). Materials with the necessary certifications are available for special applications (gas appliances and systems, drinking water, food).

**Detailed information on our products and the available certifications and conformity tests can be found in our e-Catalog or on our online ordering platform EASY.**



e-Catalog

Profil	Werkstoff	Härte [Shore A]	Temperatur [°C]	Farbe	Werkstoffeigenschaften
	NBR	70	-30 to +100	black	<ul style="list-style-type: none"> <li>• Good chemical resistance to mineral oils and greases, hydraulic oils (H, HL, HLP), the flame-resistant pressure fluids HFA and HFB. HFC up to about +50°C and water up to a maximum of +80°C</li> </ul>
		75			
		80			
		90			
	HNBR	70	-30 to +140	black	<ul style="list-style-type: none"> <li>• HNBR is formed by the full or partial hydration of NBR</li> <li>• Heat, ozone and aging stability are significantly improved in this manner. Very good mechanical characteristics, such as good wear resistance, are achieved</li> <li>• Media resistance is comparable to that of NB</li> </ul>
	EPDM, sulfur-cross	70	-45 to +130	black	<ul style="list-style-type: none"> <li>• Very stable in hot water and with steam, washing lyes, caustic soda and caustic potash, silicone oils and greases, many polar solutions, many diluted acids and chemicals</li> <li>• Good resistance to ozone</li> </ul>
	EPDM, peroxide cross	70	-50 to +150	black	<ul style="list-style-type: none"> <li>• Incompatible with mineral oil products (lubricants and fuels)</li> </ul>
	FKM	70	-20 to +200	black	<ul style="list-style-type: none"> <li>• Good chemical resistance to mineral oils and greases, synthetic oils and greases, motor, transmission and ATF oils up to +150°C, fuels, HFD flame-resistant pressure fluids, aliphatic, aromatic and chlorinated hydrocarbons, water up to a maximum of +80°C</li> <li>• Very good weathering, ozone and aging resistance</li> <li>• Very low gas permeability (thus well-suited for vacuum uses)</li> </ul>
75		green			
80		black			
90		green			
	FKM, peroxide cross	75	-15 to +200	black	
	VMQ	70	-55 to +200	red-brown	<ul style="list-style-type: none"> <li>• Good chemical stability in water (up to +100°C), aliphatic engine and transmission oils, animal- and plant-based oils and greases</li> <li>• Not resistant to fuels, aromatic mineral oils, water vapor (short periods up to a maximum of +120°C are possible), sili-cone oils and greases, along with acids and alkaline compounds</li> </ul>
	PTFE		stat. use -200 to +260 dyn. use -100 to +260	white	<ul style="list-style-type: none"> <li>• Good chemical resistance to aggressive acids, bases, alcohols and oils</li> <li>• Resistance to high and extremely low temperatures</li> </ul>

Profile	Material	Hardness [Shore A]	Temperature [°C]	Color	Material characteristics
	FKM FEP- encapsulate		-20 to +205	transparent/ black	<ul style="list-style-type: none"> <li>Including an elastic FKM</li> </ul>
	VMQ FEP- encapsulate		-60 to +205	transparent/ red-brown	<ul style="list-style-type: none"> <li>Including an elastic VMQ</li> </ul>

### STANDARD DIMENSIONS

Dichtomatik brand products are stocked in the standard dimensions of DIN ISO 3601-1 and AS568B/BS1806. In addition, different sizes of JIS 2401 (General Industry) and Norm R (NFT 47-501) are also available from stock.

### TOLERANCES / SURFACE DEVIATIONS

- Dimensional tolerances in accordance with DIN ISO 3601-1, industry class B
- Surface deviations in accordance with DIN ISO 3601-3, type feature N
- For special applications, the permissible tolerances for special items are limited to industry class A and to the type feature S for shape and surface deviations

An overview of the dimensions and tolerances currently available can be found online in our e-Catalog and on our online ordering platform EASY.

### SURFACE COATING

Dichtomatik O-rings are available on request with various surface coatings that are specially adapted to the application or the required properties. A surface coating can be used to make assembly easier, provide optimized abrasion resistance or be used for color differentiation. If you have any questions regarding the application or the selection of a suitable coating, we will be happy to advise you.



## QUALITY ASSURANCE

For Dichtomatik brand products, we actively strive for product quality with a zero-defect target through coordination with customers and production. Our batch tracing system allows every step in the supply chain to be traced

back and for statements to be made regarding product characteristics and ingredients. Batch information is provided on the product labels as well as on the corresponding delivery bills.

## DIMENSIONAL INSPECTION

The measurement of the inner diameter ( $\varnothing d1$ ) is preferably performed with the help of non-contact optical measuring machines and measuring microscopes. For large dimensions, conical and step plug gauges are also used. For O-rings with an inner diameter of more than 250 mm, circumferential measuring tapes are also used. The O-ring cross section (cord thickness  $\varnothing d2$ ) is measured with a force-reduced measuring probe. The contact force exerted between the probe surfaces should be 1 N. The dimensional tolerances are based on DIN ISO 36011, Industrial Class B.

## HARDNESS TEST

For hardness measurements on finished products, measuring systems such as IRHD (International Rubber Hardness Degree) micro hardness measurement according to DIN ISO 48 and a measuring system for Micro Shore A are available. Measurements on test plates are carried out using a Shore A hardness measuring system. Appropriate fixtures and ovens are available for carrying out compression set tests. The compression set is tested in accordance with DIN ISO 8151.

## TESTING TENSILE STRENGTH AND ELONGATION AT BREAK

A tensile testing machine is used to measure the tensile strength and elongation at break, which enables measurements to be made on finished products and standard test bars by means of appropriate fixtures.

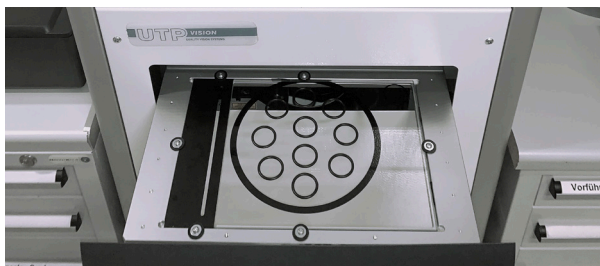

Dimensional, non-contact inspection using optical measuring machines

## SHAPE AND SURFACE TESTING

The quality specifications for Standard Dichtomatik O-rings are based on DIN ISO 36013 grade N. Special quality in accordance with grade S and other additional requirements can also be agreed as the basis for delivery. Compliance with the quality specifications is monitored using magnifying lamps and digital microscopes.

### Types of deviation

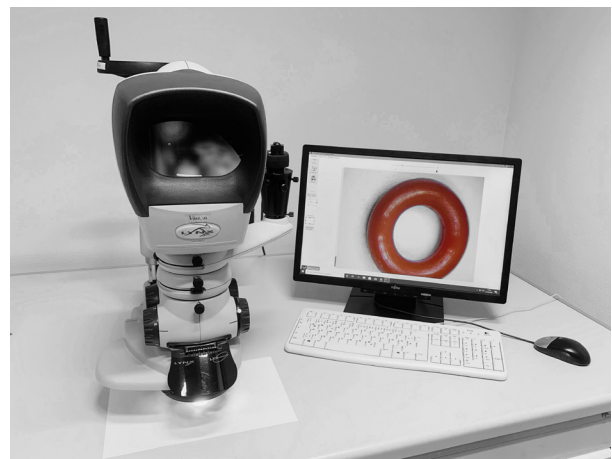
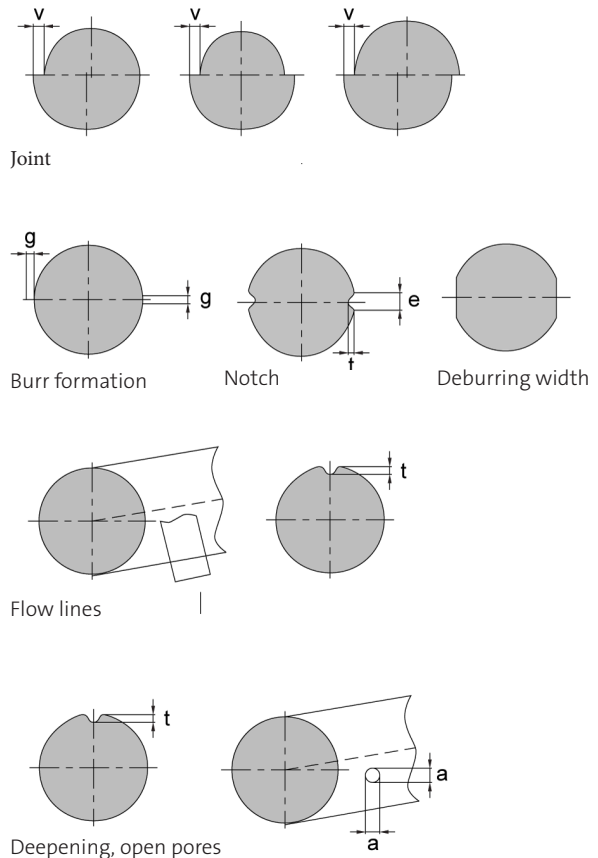

Surface inspection with a digital microscope



## MATERIALS

Dichtomatik O-rings are available in four standard and various special materials. Most of these are elastomer materials. The starting material for elastomers is rubber, which can be obtained as natural rubber but is now mainly produced as synthetic rubber in the chemical industry. Elastomers are differentiated by the underlying base polymer.

The final material is produced by mixing the base polymer with appropriate fillers, plasticizers, processing aids, vulcanizing agents, accelerators and other additives. This process

makes it possible to achieve the desired material properties and thus to offer standard materials with a wide range of applications as well as special mixtures for very specific applications.

The O-ring ultimately obtains its stable shape through the vulcanization process, in which the plastic rubber compound changes to a rubber-elastic state and the O-ring receives its final mechanical properties (hardness, tensile strength, elongation at break, compression set, ...).

# STANDARD MATERIALS

The wide range of O-ring dimensions is available from stock in four standard materials:

Base elastomer	Abbreviation	Hardness [Shore A]	Color	Temperature [°C]	
				depth	height
Nitrile butadiene rubber	NBR	70, 75, 80, 90	black	-30 -30	+100 +100
Ethylene propylene diene rubber	EPDM perox.	70	black	-50	+150
Ethylene propylene diene rubber	EPDM sulf.	70	black	-45	+130
Fluorinated rubber	FKM perox.	75	black	-15	+200
Fluorinated rubber.	FKM sulf..	80	black	-20	+200
Silicone rubber (Vinyl methyl polysiloxane)	VMQ	70	red	-55	200

The operating temperature range and media resistance are primary criteria in the selection of materials. Nevertheless, the mechanical and technological values of an elastomer

compound must be taken into account in an appropriate manner, since they are decisive for the service life of the seal.

## NBR (NITRILE BUTADIENE RUBBER)

NBR is the most commonly used material for O-rings because of its good mechanical properties and resistance to lubricating oils and greases based on mineral oil. These properties are mainly determined by the acrylonitrile content (ACN between 18% and 50%). A low ACN content results in good low-temperature flexibility but limited resistance to oils and fuels; as the ACN content increases, low-temperature flexibility decreases and oil and fuel resistance increases.

The standard NBR material for Dichtomatik O-rings has a medium ACN content to cover a wide range of applications with balanced properties. It exhibits good mechanical and technological values, e.g. high abrasion resistance, low gas permeability and good resistance to mineral oil-based lubricating oils and greases, hydraulic oils H, HL, HLP, flame-retardant hydraulic fluids HFA, HFB, HFC, aliphatic hydrocarbons, silicone oils and greases, water up to approx. +80 °C.

NBR, on the other hand, is generally not resistant to aromatic and chlorinated hydrocarbons, fuels with a high aromatic content, polar solvents, glycol-based brake fluids and flame-retardant hydraulic fluids HFD. The resistance to ozone, weathering and aging is low. However, this does not have a negative effect in the majority of applications.

## FKM (FLUORINATED RUBBER)

FKM materials are characterized by their very high temperature and chemical resistance. In addition, the very good resistance to aging and ozone as well as the very low gas permeability (good suitability for vacuum applications) and the self-extinguishing fire behavior are also worth mentioning.

The FKM standard material for O-rings shows very good resistance properties in mineral oils and fatty, aliphatic, aromatic and chlorinated hydrocarbons, fuels, hardly inflammable pressure fluids HFD and many organic solvents and chemicals.

In addition to the standard FKM materials, various special compounds are available, which are tailored to special applications through different compositions of the polymer chains and varying fluorine contents (65% to 71%).

FKM is generally not resistant to hot water, steam, polar solvents, glycol-based brake fluids and low-molecular organic acids.

### EPDM (ETHYLENE PROPYLENE DIENE RUBBER)

EPDM materials generally exhibit good hot water, steam, aging and chemical resistance and a wide thermal application range. They are divided into the sulfur and peroxide cross-linked types, whereby the peroxide compounds have a higher thermal load capacity and a significantly lower compression set.

EPDM has good resistance to hot water and steam, detergents, sodium hydroxide and potassium hydroxide solution, silicone oils and greases, many polar solvents and a large number of diluted acids and chemicals. Special qualities are recommended for glycol-based brake fluids. EPDM materials are absolutely incompatible with all mineral oil products (lubricants, fuels). The temperature application limits are from -45 °C to +130 °C (-50 °C to +150 °C peroxide cured).

### VMQ (VINYL METHYL POLYSILOXANE)

Silicone rubbers are characterized in particular by their wide thermal application range and excellent resistance to ozone, weathering and aging. The mechanical properties of silicone are rather low compared to other elastomers. In general, silicone materials are physiologically harmless, i.e. they are used in food-related and medical areas, among others.

The standard silicone material can be used in a temperature range from -55 °C to +200 °C and is resistant to water (up to +100 °C), aliphatic motor and gear oils, animal and vegetable oils and fats. Silicone is generally not resistant to fuels, aromatic mineral oils, steam (short-term up to +120 °C possible), silicone oils and greases, acids and alkalis.

## MATERIAL CERTIFICATIONS

In addition to the usual requirements for O-ring materials, special proof or certification regarding material suitability is required in certain applications. Particularly where seals are used in safety-related, food-related or medical areas, it is advisable to regulate and monitor the materials used. This includes certifications for the following applications:

- Gas installations, gas appliances, gas supply
- Drinking water fittings, drinking water supply
- The food Industry

In addition to the various standard materials, a large number of special materials are available for special applications, which are certified for use in the food and pharmaceutical industries, for example.

A complete list of the special materials and available certifications can be found on our web site.



**Dichtomatik-  
Website**



## COMPARATIVE PRESENTATION OF SOME ELASTOMER PROPERTIES

Properties	Materials									
	NBR	FKM	EPDM Sulfur	EPDM peroxid	VMQ	HNBR	FFKM	FVMQ	CR	AU/EU
Compression set	1	1	3	1	2	1	3	2	2	3
Tearability	2	2	3	2	4	1	2	3	2	1
Abrasion resistance	2	2–3	2	2	4	2	3	3	2	1
Resistance to aging	4	1	2	2	1	2	1	1	2	1
Ozone resistance	4	1	2	2	1	2	1	1	2	1
Oil and grease resistance	2	1	5	5	3	2	1	2	3	2
Gasoline resistance	4**	2**	5	5	4	3	1	2	3	3
Hot water resistance	+60**	+60**	+130	+150	+100	+100**	***	+100	+80	+50
Steam resistance	–	–	+130	+175	+120*	–	***	+120*	–	–
Heat resistance standard materials [°C]	+100	+200	+130	+150	+200	+150	+260	+175	+100	+100
Heat resistance special materials [°C]	+120	–	–	–	+250	–	+330	–	–	–
Cold resistance standard materials [°C]	-30	-15	-45	-50	-55	-30	-15	-55	-40	-40
Cold resistance special materials [°C]	-50	-35	–	–	–	-40	-35	–	-50	–

1 = very good / 2 = good / 3 = moderate / 4 = low / 5 = weak / \* = short term / \*\* = better only with a special mixture / \*\*\* = mixture dependent

### Surface treatment/gliding intensification

The typical properties of elastomer materials also include “non-gliding” and “adhesive” surfaces. In certain applications and during the assembly of O-rings (especially with automatic feed), the friction that arises can have a negative effect. A reduction in friction to facilitate assembly and even extend service life can be achieved by using various methods of gliding intensification. A distinction is made between:

- short-term gliding intensification, e.g. to facilitate assembly through
  - siliconizing
  - graphitizing
  - molykotizing
  - talcumizing
- longer-term gliding intensification through
  - halogenation (fluorination)
  - PTFE coating
  - Introduction of dry lubricants into the surface
- long-term friction reduction through gliding intensifying additives in the elastomer compound, such as molybdenum disulfide (MoS<sub>2</sub>) or polytetrafluorethylene (PTFE)

# TERMS

## TENSILE STRENGTH, ELONGATION AT BREAK

The execution of the tensile test is described in DIN 53504. A standardized tensile test specimen is stretched until it breaks. The tensile strength (tearing strength) of a material [ $\text{N}/\text{mm}^2$ ] is the force [ $\text{N}$ ] necessary to tear a sample in relation to the initial cross section of the sample [ $\text{mm}^2$ ].

The elongation at break (tearing elongation) [%] is the elongation of a marked gauge length on the standard sample at the moment of tearing in relation to the original gauge length.

The values for tensile strength and elongation at break on the finished O-ring can lead to lower results due to the geometry deviating from the standard test specimen. This aspect should be taken into account when assessing the mountability of small O-rings over larger diameters.

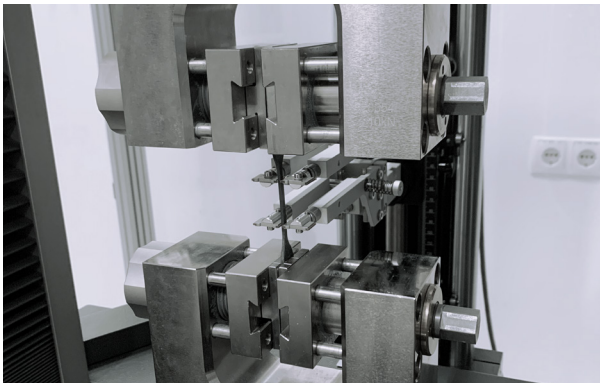

Tensile test on a standard test object

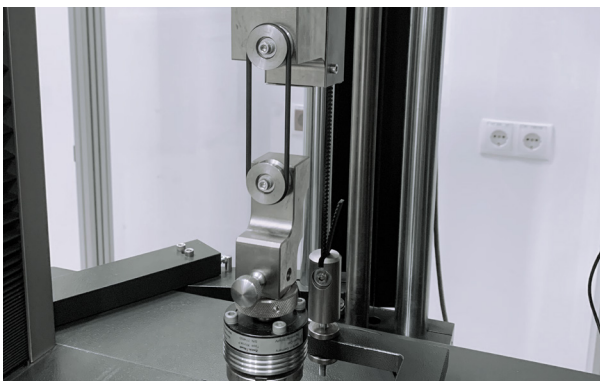

Tensile test on the final O-ring product

## TEAR PROPAGATION RESISTANCE

The tear propagation resistance [ $\text{N}/\text{mm}$ ] is the force that opposes tear propagation when a standard specimen of a corresponding thickness is cut into a defined area. The tear propagation test is described for two different specimens in DIN 53507 and DIN 53515. The value determined in this way can be used to estimate the sensitivity of an elastomer to tear propagation of cut damage.

## COLD RESISTANCE

The mechanical and technological properties of elastomers change with decreasing temperatures. For example, hardness and tear strength increase while elongation at break decreases. Above a certain temperature, the material becomes so hard and brittle that it breaks like glass under load. If the material is not mechanically stressed in the frozen state (e.g. during storage), it regains its original properties after heating.

Various tests are available to assess the flexibility at low temperatures. Frequently quoted values include the brittleness point according to DIN 53546 and the TR10 temperature according to ASTM D 1329. Interpretation of these values allows for conclusions to be made on the practical limits of low-temperature use.

## COMPRESSION SET DVR

Depending on the compound composition, time, temperature and deformation, elastomer materials exhibit, in addition to elastic behavior, a degree of plastic deformation or "flow." A component that has been deformed over a long period of time in the installation space no longer returns 100% to its original cross section after disassembly, but retains a proportion of permanent deformation.

The DVR is tested according to DIN 53517 or ASTM D 395 B and can be in the range of 0% to 100%, whereby 0% represents the ideal value and 100% the worst possible result. The DVR is calculated as follows:

$$\text{DVR} = \frac{d_0 - d_2}{d_0 - d_1} \times 100$$

$d_0$  = original thickness of the sample

$d_1$  = thickness of the specimen in deformed state

$d_2$  = thickness of the sample after relaxation

When assessing a value for the compression set, it is important to pay close attention to the test parameters. For example, the same material can achieve better or worse results by changing the temperature in the test. The same applies to the duration of the test.

### PROPERTY CHANGE AFTER AGING

In order to assess the aging behavior and suitability of materials in certain media, the changes in properties of the materials after storage in these media are determined.

DIN 53508 describes artificial aging in air. The determination of the behavior of elastomers in liquids, vapors and gases is described in DIN 53521. Here, for example, the absolute change in hardness and the percentage change in tensile strength, elongation at break and volume are determined in relation to the values of the unaged samples.

### STORAGE OF ELASTOMER PRODUCTS

The physical properties of seals made of elastomer materials and plastics can change during long-term storage. Due to the aging process, surface changes can sometimes lead to defects. Measures can be taken to minimize influencing factors such as humidity, heat, light, oxygen, ozone and radioactive radiation. These are laid down in international standards.

The maximum storage period for seals made of elastomer materials depends on the type of elastomer in question and compliance with the storage guidelines in accordance with DIN 7716 (Rubber products – Requirements for storage, cleaning and maintenance) and ISO 2230 (Rubber products – Guidelines for storage).

Different types of sealing materials also have different storage and usage times. After this period, it is important to check the materials. If there is no damage, the storage time can be extended. Depending on the geometry, pre-assembled parts must be checked at least every six months. In order to achieve the longest possible service life of seals, they should be stored and shipped in packaging made of PE-coated packing paper, aluminum foil or opaque PE film.

### ESSENTIAL REQUIREMENTS FOR STORAGE CONDITIONS

- Temperature: The storage temperature should be between 10 °C and +25 °C. Higher temperatures can lead to a reduction in service life
- Heating: The elastomer products should be shielded against heat sources. Heaters in storage rooms should be placed at a distance of at least 1 m from the stored goods
- Air humidity: The relative humidity should not exceed 65%
- Seals should be protected against strong air exchange, especially draughts. They can be stored in packaging, e.g. polyethylene bags or airtight containers
- Strong light influence, especially UV radiation and direct sunlight, should be avoided
- Electrical equipment that generates ozone should not be installed in storage rooms for elastomers
- It must be ensured that the seals are stored free of stress, i.e. without tension, pressure or other deformations



# INSTALATION SPACES AND DESIGN RECOMMENDATIONS

## STATIC SEALS

The installation spaces (grooves) for O-rings should be recessed at right angles if possible. The dimensions for the required groove depth and groove width depend on the respective application and cord thickness. The dimensions listed are recommendations for the corresponding installation type and refer to the nominal dimensions. They should be observed because the sealing function depends on the exact design of the installation space.

O-rings are well suited for static sealing. One speaks of static or stationary sealing if the machine elements to be sealed do not move relative to each other. If the installation space is properly designed, the design is correct and the right material is selected, O-rings can be used to seal pressures of up to 1,000 bar (if necessary, back-up rings must be used).

## DYNAMIC SEALS

It is also possible to use O-rings in dynamic applications. The prerequisites are:

- lower pressures and speeds
- small installation spaces
- due to the frictional resistance, a lower compression should be chosen than for static sealing
- good lubrication to avoid friction losses or premature wear due to dry running

## STATIC SEALS – RADIAL SEALS

The O-ring cross-section is radially deformed in the application, i.e. in the direction of the center of the stud/tube. Depending on the position of the groove, a distinction is made between radially inner sealing and radially outer sealing.

### GROOVE DIMENSIONS

d2 [mm]	Groove depth $t^{+0,05}$ [mm]	Groove width $b^{+0,25}$ [mm]	Fiber length C [mm]
1	0,75	1,3	1,2
1,2	0,9	1,6	1,2
1,25	0,9	1,7	1,2
1,3	1	1,7	1,2
1,5	1,1	2	1,5
1,6	1,2	2,1	1,5
1,78	1,3	2,4	1,5
1,8	1,3	2,4	1,5
1,9	1,4	2,5	1,5
2	1,5	2,6	2
2,2	1,7	3	2
2,4	1,8	3,2	2
2,5	1,9	3,3	2
2,6	2	3,4	2
2,62	2	3,5	2
2,65	2	3,6	2
2,7	2,1	3,6	2
2,8	2,2	3,7	2
3	2,3	3,9	2,5
3,1	2,4	4	2,5
3,5	2,7	4,6	2,5
3,53	2,7	4,7	2,5
3,55	2,8	4,7	2,5
3,6	2,8	4,8	2,5
3,7	2,9	4,9	2,5

d2 [mm]	Groove depth $t^{+0,05}$ [mm]	Groove width $b^{+0,25}$ [mm]	Fiber length C [mm]
4	3,2	5,2	3
4,3	3,4	5,6	3
4,5	3,6	5,8	3
5	4	6,5	3
5,3	4,3	7	3
5,33	4,3	7,1	3,5
5,5	4,5	7,2	3,5
5,7	4,6	7,6	3,5
6	4,9	7,9	3,5
6,5	5,4	8,4	4
6,99	5,8	9,2	4
7	5,8	9,3	4
7,5	6,3	9,8	4
8	6,7	10,5	4
8,4	7,1	10,9	4,5
8,5	7,2	11	4,5
9	7,7	11,7	4,5
9,5	8,2	12,3	4,5
10	8,6	13	5
10,5	9	13,8	5
11	9,5	14,3	5
12	10,5	15,6	5
15	13,2	19,2	5

**MOUNTING SITUATION**  
**RADIAL INNER SEALING**

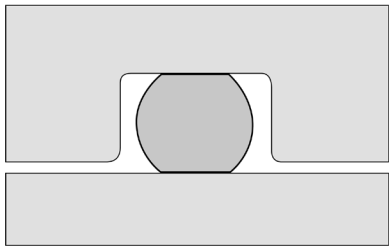

**RADIAL OUTER SEALING**

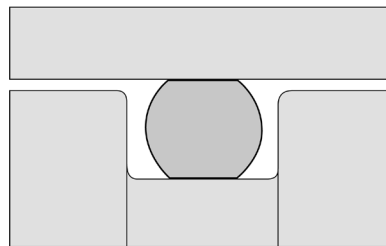

**TECHNICAL DRAWING**

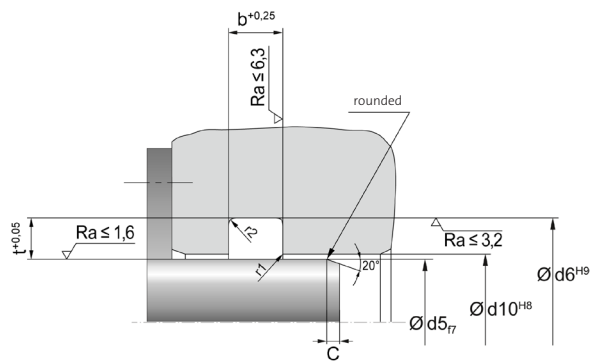

- d5\* rod diameter
- d6\* groove outside diameter
- d10\* bore diameter
- t groove depth
- b groove width

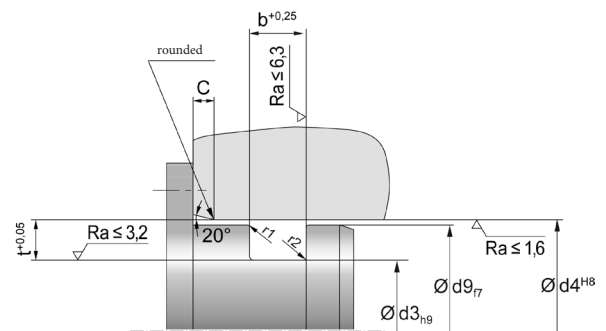

- d3\* groove inside diameter
- d4\* bore diameter
- d9\* piston diameter
- t groove depth
- b groove width

## STATIC SEALS – AXIAL SEALING

This type of installation is mainly used for flange and cover gaskets. The O-ring cross section is axially deformed.

For axial installation, the cover screw connections should be very strong so that the gap between the sealing surfaces does not exceed the permissible size even under high pressures, which could cause the O-ring to be squeezed out.

### GROOVE DIMENSIONS

d2	Groove depth $t^{+0,05}$	Groove width $b^{+0,25}$
1	0,7	1,4
1,2	0,9	1,6
1,25	0,9	1,7
1,3	1	1,7
1,5	1,1	2,1
1,6	1,2	2,2
1,78	1,3	2,5
1,8	1,3	2,6
1,9	1,4	2,7
2	1,5	2,8
2,2	1,6	3,1
2,4	1,8	3,3
2,5	1,9	3,5
2,6	2	3,6
2,62	2	3,7
2,65	2	3,8
2,7	2,1	3,8
2,8	2,1	4
3	2,3	4,1
3,1	2,4	4,2
3,5	2,7	4,8
3,53	2,7	4,9
3,55	2,7	5
3,6	2,8	5,1
3,7	2,9	5,2

d2	Groove depth $t^{+0,05}$	Groove width $b^{+0,25}$
4	3,1	5,5
4,3	3,3	5,9
4,5	3,5	6,1
5	4	6,7
5,3	4,2	7,2
5,33	4,2	7,3
5,5	4,5	7,4
5,7	4,6	7,6
6	4,8	8,1
6,5	5,3	8,6
6,99	5,7	9,7
7	5,7	9,7
7,5	6,2	10,1
8	6,6	10,7
8,4	7,1	11,1
8,5	7,2	11,3
9	7,6	12
9,5	8,1	12,5
10	8,5	13,6
10,5	8,9	14
11	9,4	14,7
12	10,4	15,7
15	13,2	19,4



**MOUNTING SITUATION**

AXIAL; PRESSURE FROM THE INSIDE

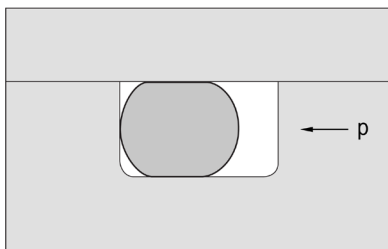

AXIAL; PRESSURE FROM THE OUTSIDE

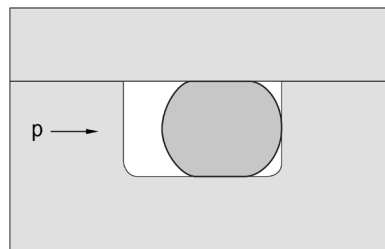

**TECHNICAL DRAWING**

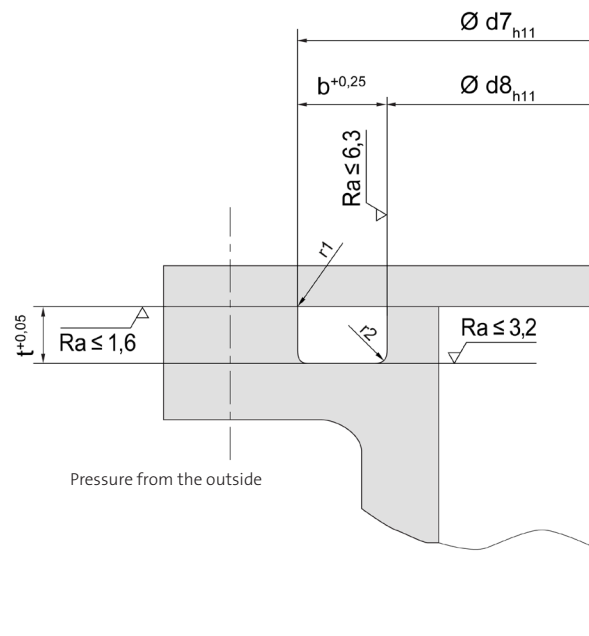
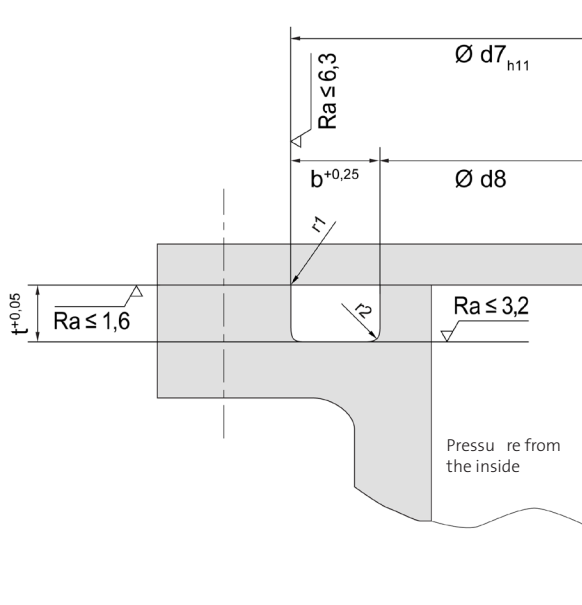

- d7 groove outer diameter
- d8 groove inner diameter
- t groove depth
- b groove width

## STATIC SEALS – TRAPEZOIDAL GROOVE

The production of a trapezoidal groove is difficult and costly. This groove geometry only makes sense if loss prevention is necessary during assembly or application.

The use of a trapezoidal groove is recommended preferably only above a cord thickness of 2 mm.

### GROOVE DIMENSIONS

d2	Groove depth $t^{\pm 0,05}$	Groove width $b^{\pm 0,05}$	r2	r1
2	1,5	1,6	0,4	0,25
2,2	1,6	1,7	0,4	0,25
2,4	1,8	1,9	0,4	0,25
2,5	2	2	0,4	0,25
2,6	2,1	2,1	0,4	0,25
2,62	2,1	2,1	0,4	0,25
2,65	2,1	2,1	0,4	0,25
2,7	2,2	2,1	0,4	0,25
2,8	2,3	2,2	0,4	0,25
3	2,4	2,4	0,4	0,25
3,1	2,5	2,5	0,4	0,25
3,5	2,8	2,9	0,8	0,25
3,53	2,8	2,9	0,8	0,25
3,55	2,8	2,9	0,8	0,25
3,6	2,9	3	0,8	0,25
3,7	3	3,1	0,8	0,25
4	3,2	3,3	0,8	0,25
4,3	3,3	3,6	0,8	0,25

d2	Groove depth $t^{\pm 0,05}$	Groove width $b^{\pm 0,05}$	r2	r1
4,5	3,7	3,7	0,8	0,25
5	4,2	4	0,8	0,25
5,3	4,6	4,2	0,8	0,4
5,33	4,6	4,2	0,8	0,4
5,5	4,7	4,4	0,8	0,4
5,7	4,9	4,5	0,8	0,4
6	5,1	4,7	0,8	0,4
6,5	5,6	5,1	0,8	0,4
6,99	6	5,6	1,6	0,4
7	6	5,6	1,6	0,4
7,5	6,4	6,1	1,6	0,4
8	6,9	6,3	1,6	0,4
8,4	7,3	6,7	1,6	0,5
8,5	7,4	6,8	1,6	0,5
9	7,8	7,2	1,6	0,5
9,5	8,2	7,7	1,6	0,5
10	8,7	8	1,6	0,5

### MOUNTING SITUATION

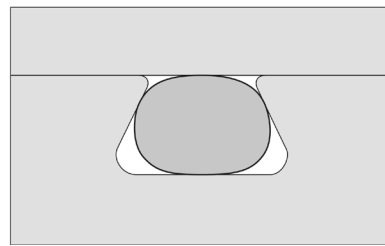
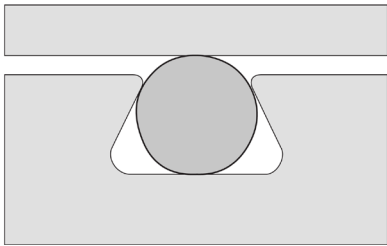

### TECHNICAL DRAWING

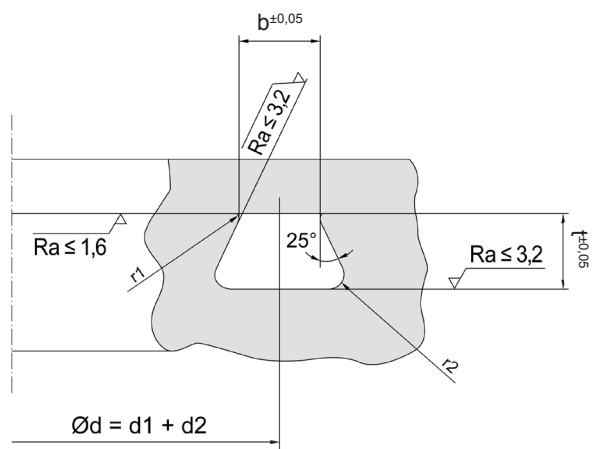

- t groove depth
- b groove width

## STATIC SEALS – TRIANGULAR GROOVE

A triangular groove should only be selected if design conditions make this necessary, e.g. in individual cases with bolted flange and cover seals.

The problem with this special groove geometry is to guarantee a defined compression of the O-ring and the small space of the groove in case of swelling of the O-ring due to media influence.

### GROOVE DIMENSIONS

d2 [mm]	Side length b [mm]	Tolerance [+] [mm]	r1 [mm]
1	1,45	0,1	0,25
1,2	1,7	0,1	0,25
1,25	1,75	0,1	0,25
1,3	1,8	0,1	0,3
1,5	2,1	0,1	0,3
1,6	2,15	0,1	0,3
1,78	2,4	0,1	0,3
1,8	2,45	0,1	0,3
1,9	2,6	0,1	0,4
2	2,75	0,1	0,4
2,2	3	0,1	0,4
2,4	3,25	0,15	0,4
2,5	3,4	0,15	0,5
2,6	3,55	0,15	0,5
2,62	3,6	0,15	0,5
2,65	3,6	0,15	0,5
2,7	3,7	0,15	0,6
2,8	3,8	0,15	0,6
3	4,1	0,2	0,6
3,1	4,25	0,2	0,6
3,5	4,8	0,2	0,8
3,53	4,8	0,2	0,8
3,55	4,85	0,2	0,8
3,6	4,9	0,2	0,9

d2 [mm]	Side length b [mm]	Tolerance [+] [mm]	r1 [mm]
3,7	5,05	0,2	0,9
4	5,5	0,2	1,2
4,3	5,9	0,2	1,2
4,5	6,15	0,2	1,2
5	6,85	0,25	1,2
5,3	7,25	0,25	1,4
5,33	7,3	0,25	1,4
5,5	7,55	0,25	1,5
5,7	7,8	0,25	1,5
6	8,2	0,3	1,5
6,5	8,9	0,3	1,7
6,99	9,6	0,3	2
7	9,6	0,3	2
7,5	10,3	0,3	2
8	11	0,4	2
8,4	11,55	0,4	2
8,5	11,7	0,4	2
9	12,4	0,4	2,5
9,5	13,05	0,4	2,5
10	13,7	0,4	2,5
10,5	14,4	0,4	2,5
11	15,1	0,4	2,5
12	16,5	0,5	3
15	20,6	0,5	3

### MOUNTING SITUATION

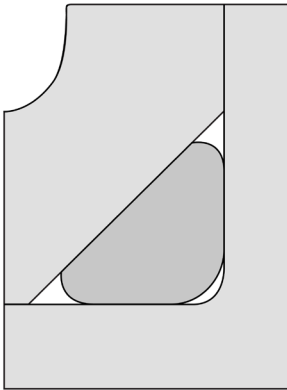

### TECHNICAL DRAWING

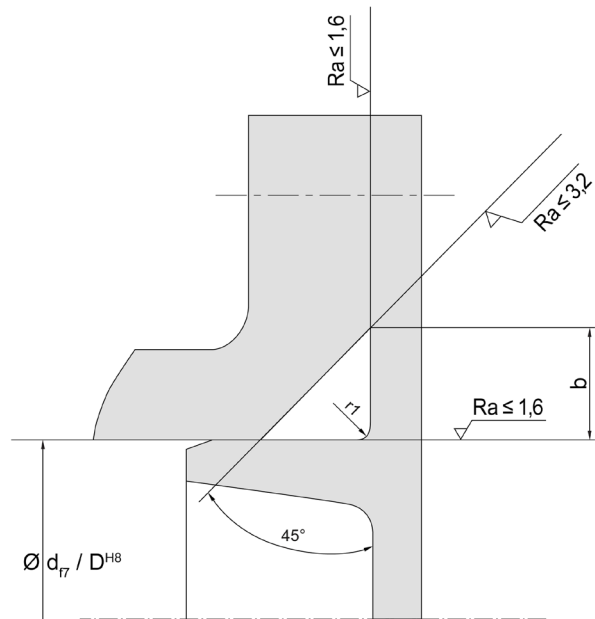

- d shaft diameter
- D bore diameter
- b side length

## STATIC SEALS – VACUUM SEALING

The vacuum seal is a special form of the static O-ring seal. Here, the system pressure to be sealed is lower than the atmospheric pressure ( $P_{atm} = 1.01325 \text{ bar}$ ). The following recommendations must be observed for vacuum sealing:

- nearly 100% filling of the groove
- elastomer material should have good gas compatibility, low permeability and a low compression set. For standard applications, we recommend the material FKM
- Compression of the O-ring cross section should be about 30%
- Use of a vacuum grease (reduction of the leakage rate)
- Significantly better surface quality (roughness depths) of groove and sealing surfaces than with static standard seals

### GROOVE DIMENSIONS

d2	Groove depth $t^{-0,05}$	Groove width $b^{\pm 0,05}$	r1	r2
1,5	1,05	1,8	0,1	0,2
1,78	1,25	2,1	0,1	0,2
1,8	1,25	2,1	0,1	0,2
2	1,4	2,3	0,1	0,3
2,5	1,75	2,9	0,1	0,3
2,6	1,8	3	0,1	0,4
2,62	1,85	3,1	0,1	0,4
2,65	1,85	3,1	0,1	0,4
2,7	1,9	3,15	0,1	0,4
2,8	1,95	3,2	0,1	0,4
3	2,1	3,5	0,1	0,6
3,1	2,2	3,6	0,1	0,6
3,5	2,45	4,1	0,2	0,6
3,53	2,5	4,1	0,2	0,6
3,55	2,5	4,15	0,2	0,6
3,6	2,5	4,2	0,2	0,6
3,7	2,6	4,3	0,2	0,6
4	2,8	4,7	0,2	0,6

d2	Groove depth $t^{-0,05}$	Groove width $b^{\pm 0,05}$	r1	r2
4,5	3,15	5,3	0,2	0,8
5	3,5	5,9	0,2	0,8
5,3	3,7	6,3	0,2	1
5,33	3,7	6,3	0,2	1
5,5	3,8	6,6	0,2	1
5,7	4	6,7	0,2	1
6	4,2	7,1	0,2	1
6,5	4,6	7,6	0,2	1
6,99	4,9	8,2	0,3	1
7	4,9	8,2	0,3	1
7,5	5,3	8,7	0,3	1
8	5,6	9,4	0,3	1
8,4	5,9	9,9	0,3	1
8,5	6	10	0,3	1
9	6,4	10,5	0,3	1
9,5	6,7	11,2	0,3	1
10	7,1	11,7	0,3	1

### MOUNTING SITUATION

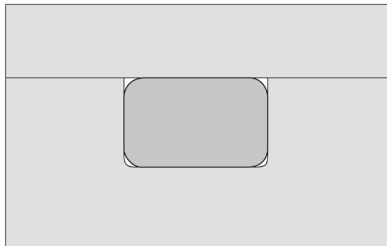

### TECHNICAL DRAWING

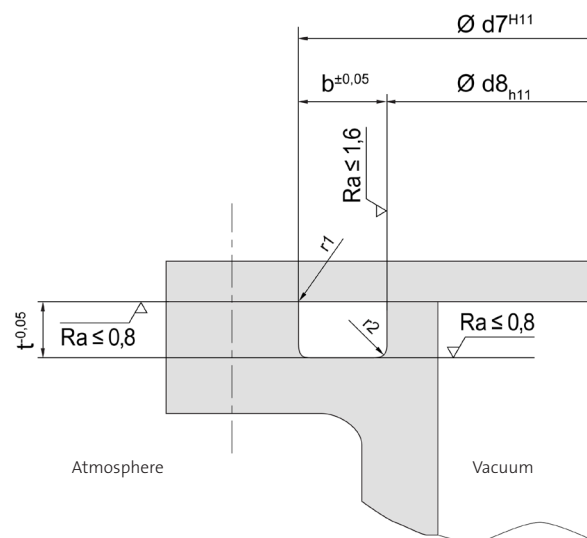

$d7^*$  groove outer diameter

$d8^*$  groove inner diameter

$t$  groove depth

$b$  groove width

\*All diameters are determined by the application.

## DYNAMIC SEALS – HYDRAULICS

O-rings should only be used as piston and rod seals in hydraulics if there is little space available for installation, if relatively short stroke distances occur and if absolutely

leak-free sealing is not required. Minimal leakage is even desirable to form a lubricating film to reduce friction and abrasion.

### GROOVE DIMENSIONS

d2 [mm]	Groove depth $t^{+0,05}$ [mm]	Groove width $b^{+0,25}$ [mm]	Fiber length C [mm]
1	0,9	1,3	1
1,2	1	1,6	1
1,25	1,1	1,6	1
1,3	1,1	1,7	1,2
1,5	1,3	1,9	1,2
1,6	1,4	2	1,2
1,78	1,5	2,3	1,3
1,8	1,5	2,4	1,3
1,9	1,6	2,5	1,3
2	1,7	2,6	1,3
2,2	1,9	2,8	1,3
2,4	2,1	3	1,4
2,5	2,2	3,1	1,4
2,6	2,2	3,3	1,5
2,62	2,2	3,4	1,5
2,65	2,3	3,4	1,5
2,7	2,4	3,4	1,5
2,8	2,4	3,6	1,6
3	2,6	3,8	1,8
3,1	2,7	3,9	1,8
3,5	3,1	4,4	2
3,53	3,1	4,5	2
3,55	3,1	4,5	2
3,6	3,1	4,6	2

d2 [mm]	Groove depth $t^{+0,05}$ [mm]	Groove width $b^{+0,25}$ [mm]	Fiber length C [mm]
3,7	3,2	4,8	2
4	3,5	5,1	2
4,3	3,8	5,5	2,5
4,5	4	5,7	2,5
5	4,4	6,4	2,7
5,3	4,7	6,8	2,9
5,33	4,7	6,9	2,9
5,5	4,9	7,1	3
5,7	5,1	7,2	3
6	5,4	7,5	3,6
6,5	5,8	8,1	3,6
6,99	6,2	8,8	3,6
7	6,2	8,9	3,6
6,7	9,4	3,8	
8	7,1	10,2	4
8,4	7,5	10,6	4,2
8,5	7,6	10,8	4,2
9	8,1	11,4	4,5
9,5	8,5	12	4,5
10	9	12,6	4,5
10,5	9,5	13,2	5
11	9,9	13,9	5
12	10,9	15,1	5
15	13,7	18,8	5



**MOUNTING SITUATION**  
**RADIAL INNER SEALING**

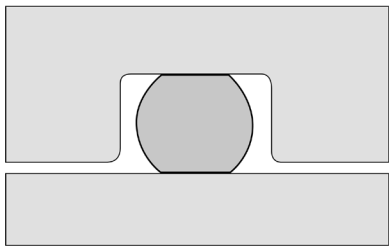

**RADIAL OUTER SEALING**

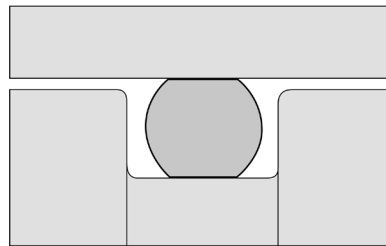

**TECHNICAL DRAWING**

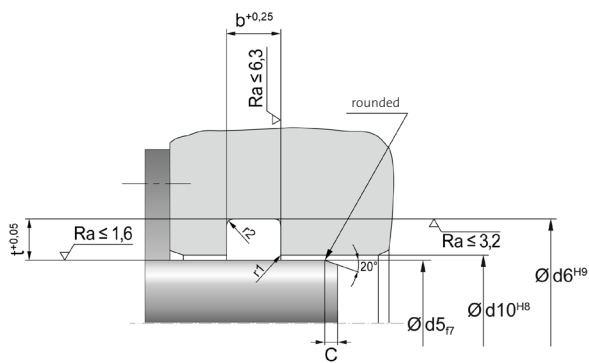

- d5\* shaft diameter
- d6\* groove base diameter
- d10\* bore diameter
- t groove depth
- b groove width

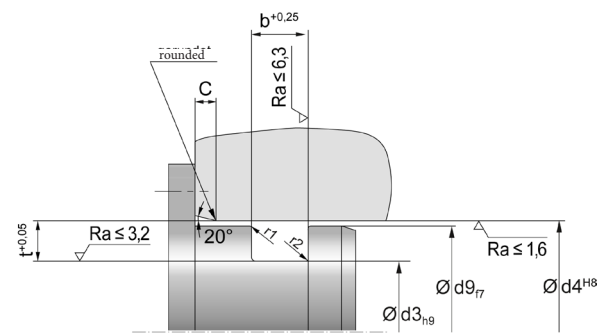

- d3\* groove inside diameter
- d4\* bore diameter
- d9\* piston diameter
- t groove depth
- b groove width

\*All diameters are determined by the application.

## DYNAMIC SEALS – PNEUMATICS

In pneumatics, O-rings are mainly used to seal translatory movements.

Please note that the O-ring is less compressed than in hydraulic applications.

### GROOVE DIMENSIONS

d2 [mm]	Groove depth $t^{+0,05}$ [mm]	Groove width $b^{+0,25}$ [mm]	Fiber length C [mm]
1	0,95	1,2	0,9
1,2	1,05	1,5	1
1,25	1,15	1,5	1
1,3	1,15	1,6	1,1
1,5	1,35	1,8	1,1
1,6	1,45	1,9	1,2
1,78	1,55	2,2	1,2
1,8	1,55	2,3	1,2
1,9	1,7	2,3	1,2
2	1,8	2,4	1,2
2,2	2	2,6	1,4
2,4	2,15	2,9	1,4
2,5	2,25	3	1,4
2,6	2,35	3,1	1,4
2,62	2,35	3,1	1,5
2,65	2,35	3,2	1,5
2,7	2,45	3,3	1,5
2,8	2,55	3,4	1,5
3	2,7	3,6	1,5
3,1	2,8	3,7	1,5
3,5	3,15	4,2	1,8
3,53	3,2	4,3	1,8
3,55	3,2	4,3	1,8
3,6	3,3	4,3	1,8
3,7	3,4	4,4	1,8

d2 [mm]	Groove depth $t^{+0,05}$ [mm]	Groove width $b^{+0,25}$ [mm]	Fiber length C [mm]
4	3,7	4,8	2
4,3	4	5,1	2
4,5	4,2	5,4	2,3
5	4,65	5,9	2,3
5,3	4,95	6,4	2,7
5,33	4,95	6,4	2,7
5,5	5,15	6,5	2,8
5,7	5,35	6,8	3
6	5,6	7,2	3,1
6,5	6,1	7,8	3,3
6,99	6,55	8,4	3,6
7	6,6	8,4	3,6
7,5	7,1	8,9	3,8
8	7,6	9,5	4
8,4	7,9	10,1	4,2
8,5	8	10,2	4,2
9	8,5	10,8	4,3
9,5	9	11,4	4,3
10	9,5	12	4,5

**MOUNTING SITUATION**  
**RADIAL INNER SEALING**

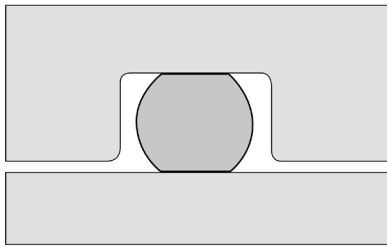

**RADIAL OUTER SEALING**

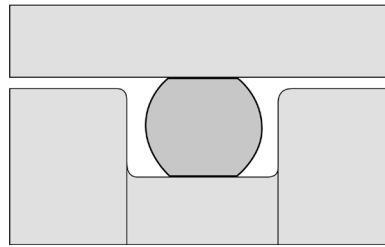

**TECHNICAL DRAWING**

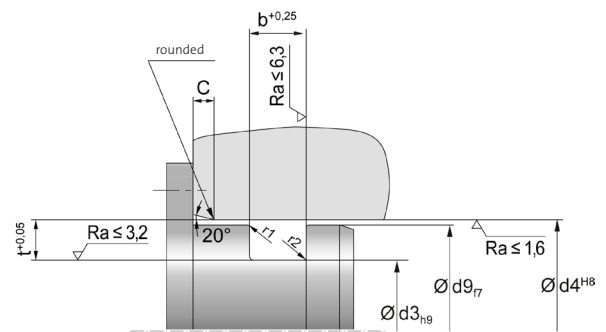
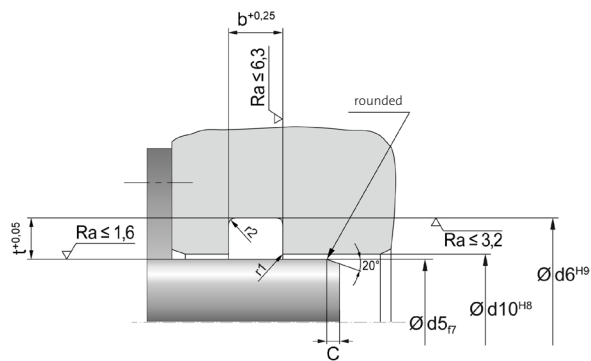

- d5\* rod diameter
- d6\* groove outside diameter
- d10\* bore diameter
- t groove depth
- b groove width

- d3\* groove inside diameter
- d4\* bore diameter
- d9\* piston diameter
- t groove depth
- b groove width

\*All diameters are determined by the application.

## DESIGN GUIDELINES

According to the dimensional and geometrical design of the installation space, the following details must be observed:

- The specification of the average roughness value Ra is often not sufficient for the classification of the surface quality. Therefore, the averaged roughness Rz and the maximum roughness Rmax are also listed
- All edges and transitions of components coming into contact with the O-ring should be completely deburred, rounded and, if necessary, polished
- The transition from the groove flank to the groove bottom (r2) and the transition from the groove flank to the component surface (r1) must be slightly rounded
- Please refer to the following table for the radii related to the cord thickness:

d2 [mm]	r1 [mm]	r2 [mm]
1 – 2	0,1	0,3
2 – 3	0,2	0,3
3 – 4	0,2	0,5
4 – 5	0,2	0,6
5 – 6	0,2	0,6
6 – 8	0,2	0,8
8 – 10	0,2	1
10 – 12	0,2	1
12 – 15	0,2	1,2

- For dynamic applications, the surface must be finer than for static applications. The same applies to pulsating pressures
- Scoring, blowholes or scratches on the surface must be avoided

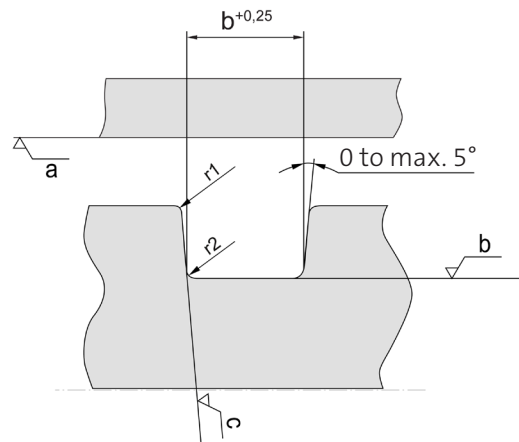

Transition groove flank to groove base (r2) and groove flank to component surface (r1)

## SURFACE FINISHES

Type of seal	Surface	Pressure	$R_a$ [ $\mu\text{m}$ ]	$R_z$ [ $\mu\text{m}$ ]	$R_{max}$ [ $\mu\text{m}$ ]
dynamic radial	Counter running surface a		$\leq 0,4$	$\leq 1,2$	$\leq 1,6$
	Groove base b		$\leq 1,6$	$\leq 3,2$	$\leq 6,3$
	Groove flanks c		$\leq 3,2$	$\leq 6,3$	$\leq 10$
static radial/axial	Counter running surface a	non-pulsating	$\leq 1,6$	$\leq 6,3$	$\leq 10$
	Groove base b		$\leq 3,2$	$\leq 10$	$\leq 12,5$
	Groove flanks c		$\leq 6,3$	$\leq 12,5$	$\leq 16$
	Counter running surface a	pulsating	$\leq 0,8$	$\leq 1,6$	$\leq 3,2$
	Groove base b		$\leq 1,6$	$\leq 3,2$	$\leq 6,3$
	Groove flanks c		$\leq 3,2$	$\leq 6,3$	$\leq 10$

The values listed in the table are standard values and might need to be checked in the specific application.

## LEAD-IN CHAMFER

In order to avoid damage to the O-ring, lead-in chamfers must be provided for.

The angles between lead-in chamfers and straight lines should be between  $15^\circ$  and  $20^\circ$ . The lengths C of the lead-in chamfers are shown in the groove design tables.

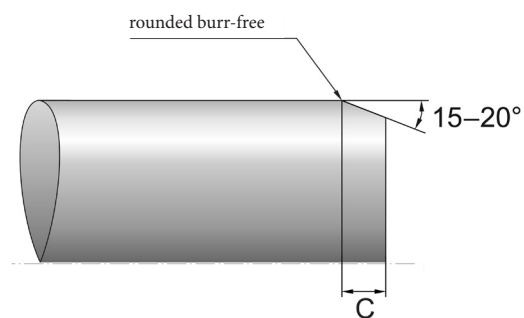

Lead-in chamfer shaft

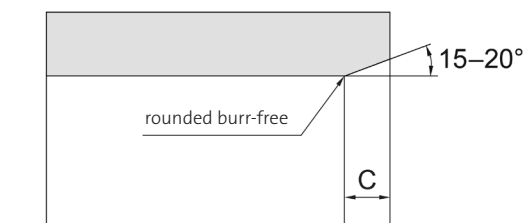

Lead-in chamfer housing

## SEALING GAP

The gap to be sealed should be as small as possible. Therefore, the fits and tolerances specified in the installation dimension tables and drawings must be observed.

In dynamic applications, there is a risk that the O-ring will be destroyed by being torn or peeled off. The use of back-up rings is recommended to protect the O-ring from gap extrusion.

Maximum permissible values for the radial sealing gap  $g$  [mm]

The permissible values for the sealing gap depend on pressure, material hardness and diameter.

The gap dimensions shown in the table apply to all elastomer materials except silicone.

For larger gap dimensions, the use of back-up rings is necessary.

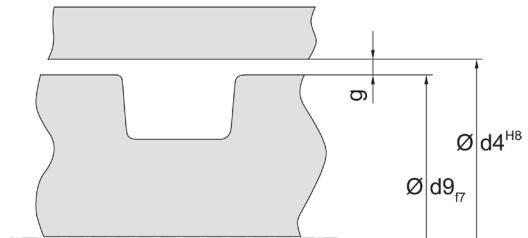

Sealing gap [g]

## GAP DIMENSIONS

Type of seal	Pressure [bar]	Hardness [Shore A]		
		70	80	90
dynamic radial	≤ 60	0,2	0,25	0,3
	> 60 – 100	0,1	0,2	0,25
	> 100 – 160	0,05	0,1	0,2
	> 160 – 250	-	0,05	0,1
	> 250 – 350	-	-	0,05
static radial/axial	≤ 30	0,2	0,25	0,3
	> 30 – 60	0,1	0,17	0,2
	> 60 – 80	-	0,1	0,15
	> 80 – 100	-	-	0,1

The values listed in the table are standard values and might need to be checked in the specific application.

## LAYOUT GUIDELINES

To achieve a good sealing effect, O-rings with the largest possible cord thickness should be chosen.

The hardness of the O-ring material chosen depends on the pressures applied, the gap widths (tolerances), the sealing type (static/dynamic) and the surface quality of the parts to be sealed. For standard applications, we recommend a material hardness of 70 Shore A. For applications, e.g. with pulsating pressures and especially for higher pressure ranges, material hardnesses up to 90 Shore A should be chosen.

### GROOVE FILLING

The degree of groove filling should be approx. 70–85%, excluding vacuum sealing. This leaves sufficient space for the O-ring in case of swelling due to media contact. In addition, the media pressure on a large part of the O-ring surface can provide the required contact pressure. The following formula applies to the groove filling:

$$\text{Groove filling} = \frac{A_{or}}{A_{nut}} \times 100 \%$$

$$A_{or} = d_2^2 \times \frac{\pi}{4} \quad A_{nut} = t \times b$$

### COMPRESSION

The sealing effect of the O-ring is created by radial or axial compression in the installation space.

For static applications, the average compression, related to the cord thickness, should be as follows:

Application	medium compression
static	15 – 30 %
dynamic (hydraulics)	10 – 18 %
dynamic (pneumatics)	4 – 12 %

The values listed in the table are standard values and might need to be checked in the specific application.

### STRETCHING AND COMPRESSION

O-rings may be stretched or compressed within certain limits during installation without affecting their sealing function.

- When installed, the O-ring should not be stretched by more than 6% in relation to the inner diameter
- The compression of the O-ring should not be greater than max. 3%, otherwise the O-ring can warp in the groove

The following formulas apply to the stretching and compression of the O-ring:

$$\text{Stretch} = \frac{(d3-d1)}{d1} \times 100 \%$$

$$\text{Compression} = \frac{(da-d6)}{da} \times 100 \%$$

$$da = (d1 + (2 \times d2))$$

d1 = O-ring inner diameter

d2 = O-ring cord thickness

d3 = groove base diameter (inside)

d6 = groove base diameter (outside)

# INSTALLATION INSTRUCTIONS

During installation, any damage to the O-ring must be avoided, otherwise leaks may occur. The following instructions should also be observed:

- For assembly, a brief, careful expansion of the O-ring of max. 20–50% is possible. The smaller the inner diameter of the O-ring, the smaller the permissible brief expansion.
- Edges must be free of burrs, radii and chamfers must be applied seamlessly
- Dust, dirt, metal chips and other particles must be removed
- Thread tips and installation spaces for other sealing and guide elements should be covered with the aid of a mounting sleeve
- Assembly surfaces and O-rings should be provided with a suitable grease
- Heating in oil or hot water to approx. +80 °C or water to approx. +60°C makes elastomers more pliable. This makes it easier to expand the O-ring for assembly
- Any assembly tools used, such as expanding mandrel or sleeves, should be made of soft material (e.g. POM) and be free of sharp edges
- The O-ring should not be rolled over the mounting surfaces. When snapping into the groove, the O-ring are not used twisted

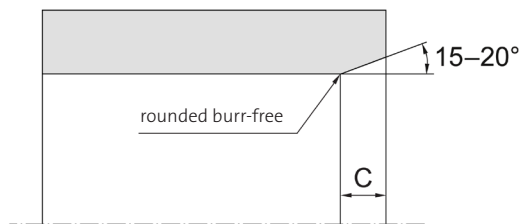

Lead-in chamfer on the housing

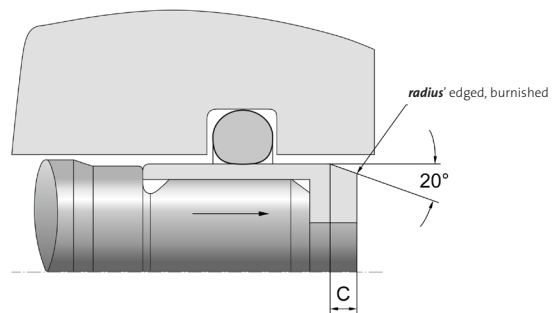

Cover by using a mounting sleeve

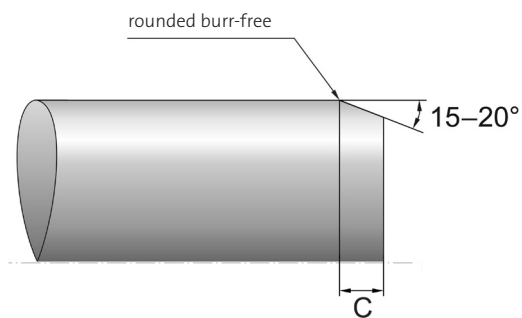

Lead-in chamfer on the shaft

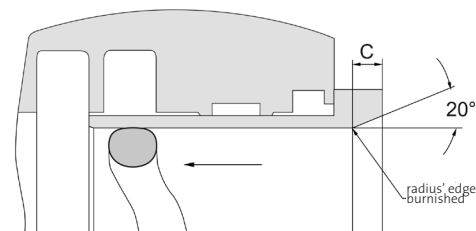

Cover by using a mounting sleeve



## BACK-UP RINGS

Back-up rings are used to prevent gap extrusion in O-rings. With increasing pressures and large sealing gaps, there is a risk that the O-ring material will be pressed into the sealing gap on the side facing away from the pressure. If this process is repeated and the pressure continues to rise, the O-ring can be irreversibly damaged and ultimately completely destroyed.

Back-up rings do not perform a sealing function. However, by reducing the sealing gap on the side facing away from the pressure, they ensure that the O-ring can assume its sealing function permanently without being damaged.

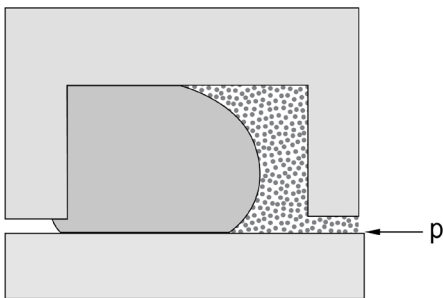

Risk of gap extrusion

### MATERIALS

The choice of material for back-up rings is primarily based on the level of pressure occurring in the application, which the back-up ring material must be able to withstand with an appropriate extrusion strength or hardness. Parameters such as the gap height, resistance to the ambient medium and the operating temperature must also be taken into account. Support rings of the STU design in NBR 90 are available from stock to match the O-ring standard dimensions. On request, other versions in PTFE or POM are also available.

### INSTALLATION SPACES

Back-up rings are usually mounted in wider installation spaces on the side facing away from the pressure. Due to the large number of standard installation spaces for O-rings on the market, the back-up ring dimensions must usually be adapted to the current installation space geometry. The following parameters are required for design:

- Groove dimensions incl. tolerances
- Type of seal:
  - static/dynamic
  - external/internal sealing
- O-ring dimensions, pressure, medium, temperature

When using back-up rings from existing dimensional series, e.g. NBR 90, the installation space must be designed in accordance with the manufacturer's specifications.

If you have any questions regarding the use or selection of back-up rings, we would be happy to advise you.

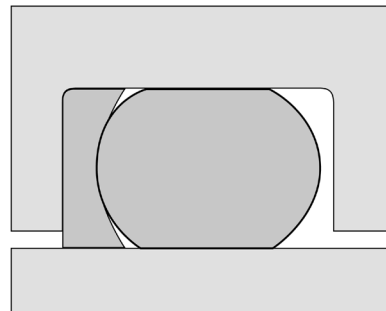

Mounting situation back-up ring

# INDUSTRY PROVEN



## COMPREHENSIVE PRODUCT PORTFOLIO FOR SEALING APPLICATIONS

Freudenberg Sealing Technologies has a broad, customer-oriented product portfolio of premium Freudenberg brand products for all applications – from customized individual solutions to complete sealing packages.

In addition, Dichtomatik brand products are ideal for several moderately demanding applications in general industry. The wide range of products is characterized by a very good price-performance ratio. Manufactured by certified external suppliers, the sealing products and solutions reliably meet

common industrial market quality standards. Additional services such as general technical support round off the range.

Freudenberg Sealing Technologies serves the entire sealing market with this complementary product portfolio and thus meets all market requirements – quickly, reliably and from a single source.

[www.fst.com](http://www.fst.com) | [dichtomatik.fst.com](http://dichtomatik.fst.com)





**Editorial information**

Freudenberg FST GmbH  
Höhnerweg 2-4  
69469 Weinheim, Germany

**Published by**

Freudenberg Industrial Services GmbH  
Albert-Schweitzer-Ring 1  
22045 Hamburg, Germany  
Tel. +49 40 669 89 0  
fis.hamburg@fst.com  
www.fst.com | dichtomatik.fst.com

**Publishing date**

December 2024

Image credits – photo at bottom of Page 6  
Workaround GmbH  
Rupert-Mayer-Str. 44  
81379 Munich, Germany