



O-RING REFERENCE AS568 SIZES

Freudenberg-NOK
Sealing Technologies

THE FREUDENBERG–NOK SEALING TECHNOLOGIES O-RING DESIGN QUICK REFERENCE

This design quick reference guide is intended for use in specifying O-ring and groove dimensions for static applications with pressures less than 1500 psi.

The guidelines are for the nominal condition. The minimum and maximum conditions should also be checked. This requires looking at the dimensionally largest possible O-ring in the smallest possible groove (i.e., at the hardware and O-ring tolerance stack-up) and the smallest possible O-ring in the largest possible groove.

Throughout this reference guide the term “compression” is used for describing what provides the sealing force. Since elastomers are essentially incompressible, the technically correct term would be “deformation.” Compression is used, as it is the more commonly used terminology in the industry.

O-RING GLAND TYPES AND NOMENCLATURE

Most static O-ring seals can be classified into one of the three arrangements shown below. The variable names

presented in these diagrams are used throughout the quick reference guide.

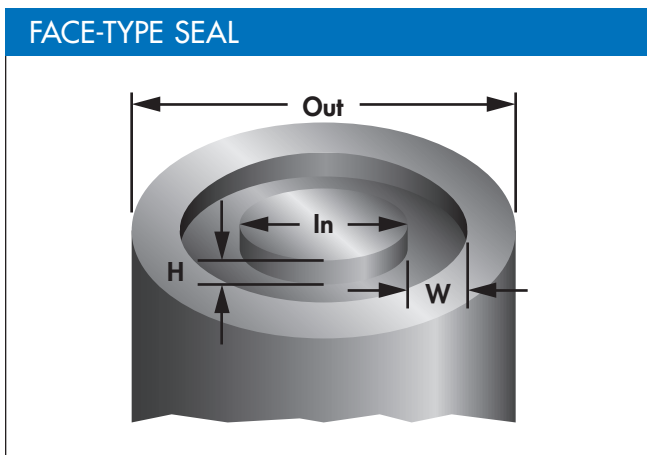
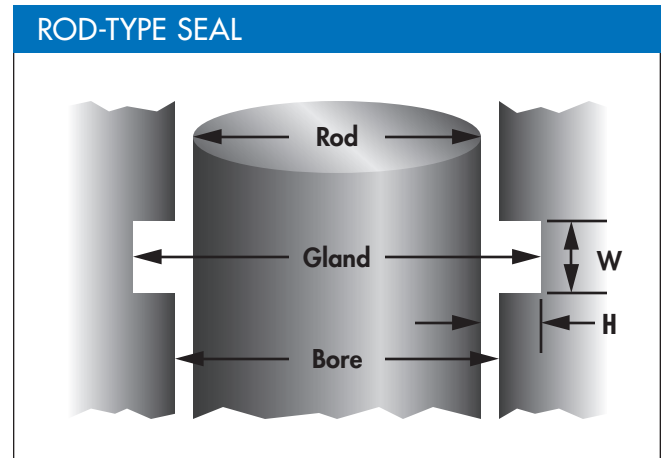
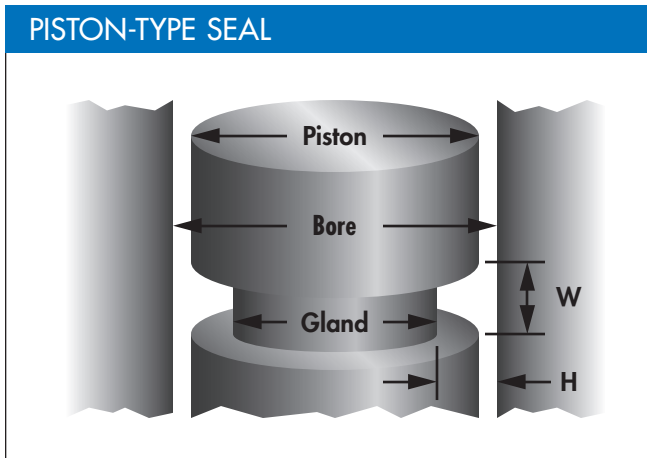

GLAND DIMENSION CALCULATIONS

Although each physical arrangement is different, typically the O-ring is captured in a rectangular gland. Two opposing surfaces are sealing surfaces, in that the distance between them, the gland height (H), is less than the O-ring cross-section (CS) so that the installed O-ring is compressed, resulting in a sealing force. The other two

opposing surfaces are containing surfaces in that the distance between them, the gland width (W), is larger than the O-ring cross-section so that they serve to keep the O-ring in place. Calculations of basic gland dimensions for piston type, rod type and face seals are shown below.

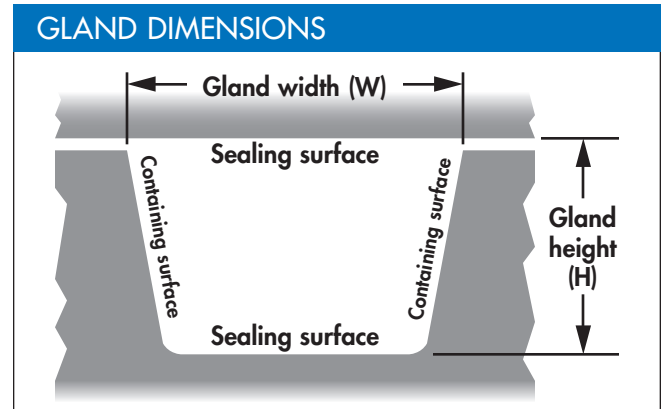
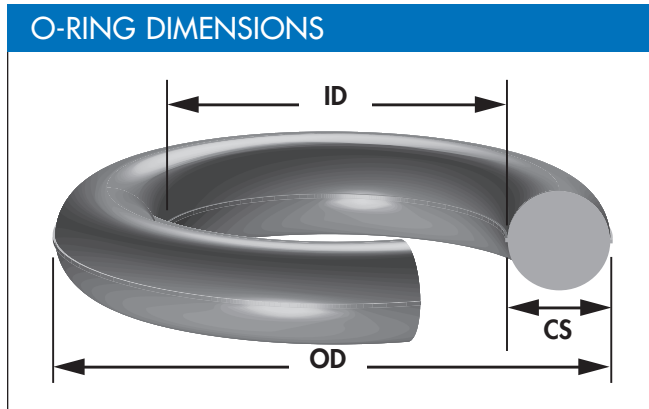

PISTON-TYPE SEAL

$$H = \frac{\text{Bore} - \text{Gland}}{2} \quad W = W$$

ROD-TYPE SEAL

$$H = \frac{\text{Gland} - \text{Rod}}{2} \quad W = W$$

FACE-TYPE SEAL

$$H = H \quad W = \frac{\text{Out} - \text{In}}{2}$$

ID STRETCH/OD INTERFERENCE

The ID or OD of the O-ring should be chosen to minimize the potential for installation damage and to minimize wear during use.

- For piston-type seals the ID of the O-ring should be smaller than the gland diameter so that the installed O-ring is always slightly stretched, even with the largest possible O-ring ID and smallest possible gland diameter.
- For rod-type seals the OD of the O-ring should be slightly larger than the gland diameter so that there is always some interference.

- For external pressure face seals, the ID of the O-ring should be slightly smaller than the inner diameter (In) so that when the pressure is applied, the O-ring is already where it would be as a result of the pressure.
- For internal pressure face seals, the OD of the O-ring should be slightly larger than the outer diameter (Out) so that when the pressure is applied, the O-ring is already where it would be as a result of the pressure.

PISTON-TYPE SEAL

$$\text{Stretch} = \frac{\text{Gland} - \text{ID}}{\text{ID}} \quad \begin{array}{l} \text{Maximum} = 5\% \\ \text{Minimum} = 0\% \end{array}$$

EXTERNAL PRESSURE FACE-TYPE SEAL

$$\text{Stretch} = \frac{\text{In} - \text{ID}}{\text{ID}} \quad \begin{array}{l} \text{Maximum} = 5\% \\ \text{Minimum} = 0\% \end{array}$$

ROD-TYPE SEAL

$$\text{Interference} = \frac{\text{OD} - \text{Gland}}{\text{OD}} \quad \begin{array}{l} \text{Maximum} = 2\% \\ \text{Minimum} = 0\% \end{array}$$

INTERNAL PRESSURE FACE-TYPE SEAL

$$\text{Interference} = \frac{\text{OD} - \text{Out}}{\text{OD}} \quad \begin{array}{l} \text{Maximum} = 3\% \\ \text{Minimum} = 0\% \end{array}$$

REDUCTION IN CROSS-SECTION

Since elastomers are essentially incompressible materials, if the ID of the O-ring is stretched, the cross-section of the O-ring will decrease. The following tables give the O-ring cross-sections that result from ID stretch. The new cross-section should be used for all compression and gland fill calculations for piston-type and external pressure face seals.

The impact of OD interference on the O-ring cross-section varies and does not typically require design considerations.

AS568 Series	Original Cross-Section in inches	Reduced Cross-Section at % ID Stretch (inches)				
		1%	2%	3%	4%	5%
-0XX	0.070 in.	.069	.069	.068	.068	.068
-1XX	0.103 in.	.102	.101	.100	.100	.100
-2XX	0.139 in.	.138	.137	.136	.135	.134
-3XX	0.210 in.	.208	.206	.205	.204	.203
-4XX	0.275 in.	.272	.270	.268	.267	.266

AS568 Series	Original Cross-Section in millimeters	Reduced Cross-Section at % ID Stretch (millimeters)				
		1%	2%	3%	4%	5%
-0XX	1.78 mm	1.76	1.75	1.74	1.73	1.72
-1XX	2.62 mm	2.59	2.57	2.56	2.55	2.53
-2XX	3.53 mm	3.49	3.47	3.44	3.43	3.41
-3XX	5.33 mm	5.28	5.24	5.20	5.18	5.15
-4XX	6.99 mm	6.92	6.87	6.82	6.79	6.75

COMPRESSION SQUEEZE

Compression squeeze is the difference between the original O-ring cross-section (CS) and the gland height (H). It is expressed in either inches or mm.

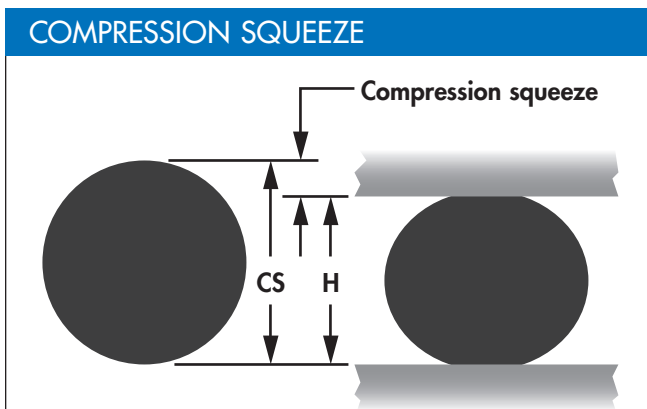

CALCULATION

$$\text{Compression Squeeze} = \text{CS} - \text{H}$$

RECOMMENDED MINIMUM VALUE

$$\text{Compression Squeeze} > 0.005 \text{ inch (0.1 mm)}$$

COMPRESSION RATIO

The compression ratio is the ratio between compression squeeze and the uncompressed O-ring cross-section.

Compression ratio is typically expressed as a percentage.

CALCULATION

$$\text{Compression Ratio (\%)} = \frac{\text{Compression Squeeze}}{\text{CS}} \times 100$$

RECOMMENDED VALUE

Piston- or Rod-Type Seal

Minimum: 5% Target: 20% Maximum: 30%

Face-Type Seal

Minimum: 10% Target: 25% Maximum: 35%

GLAND FILL

Gland fill is the percentage of the gland that is occupied by the O-ring. It is calculated by dividing the cross-sectional area

(CSA) of the O-ring by the cross-sectional area of the gland.

O-RING CROSS-SECTION AREA

$$\text{O-Ring CSA} = \pi \times \left(\frac{\text{CS}}{2}\right)^2$$

GLAND CROSS-SECTION AREA

$$\text{Gland CSA} = H \times W^*$$

GLAND FILL

$$\text{Gland Fill (\%)} = \frac{\text{O-Ring CSA}}{\text{Gland CSA}} \times 100$$

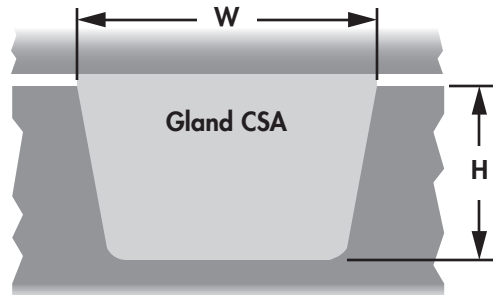
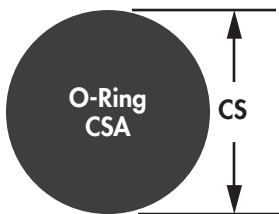

* Effect of gland angle not addressed

The following target gland fill recommendations take into account several hardware and O-ring-related factors including but not limited to thermal expansion, volume swell due to fluid exposure, and the effect of tolerance stack-ups.

A gland fill as low as 50% and as high as 90% is acceptable, but it is recommended that the targets shown below be adhered to whenever possible.

RECOMMENDED VALUES

Target Minimum: 65% Target: 75% Target Maximum: 85%

EXTRUSION GAP

Extrusion is a concern for radial seals where there is a gap between the piston and the bore for a piston-type seal or between the rod and the bore for a rod-type seal. It is not typically a concern for face seals where the metal parts to be sealed are in contact line-to-line. The issue is that at higher pressures and especially for softer O-ring elastomers,

the O-ring can be forced by the pressure into the small gap between the piston or rod and the bore. Unless the hardware can ensure the bore and the piston or rod remain concentric, we have to assume that all of the gap possible can shift to one side (see diagram below).

PISTON-TYPE SEAL

Extrusion Gap = Bore – Piston

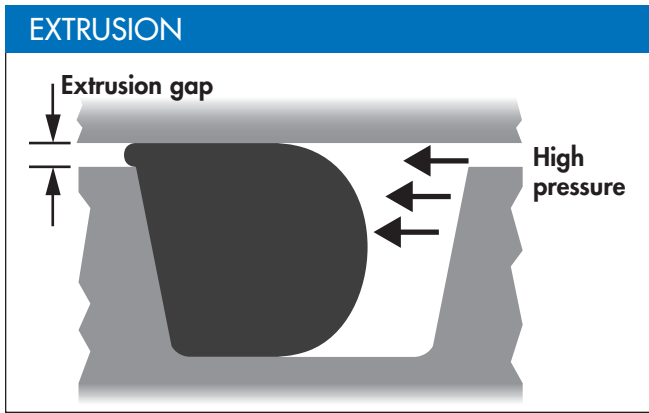

ROD-TYPE SEAL

Extrusion Gap = Bore – Rod

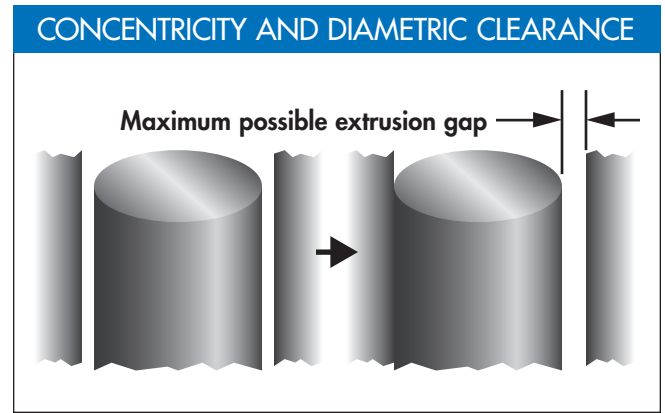

Maximum Recommended Extrusion Gap in Inches (mm)

Pressure (psi)	Elastomer Hardness (durometer)			
	60	70	80	90
500	.010 (.25)	.015 (.38)	.020 (.51)	.025 (.64)
750	.005 (.13)	.011 (.28)	.016 (.41)	.023 (.58)
1000	.002 (.05)	.008 (.20)	.012 (.30)	.018 (.46)
1250	.001 (.02)	.004 (.10)	.009 (.23)	.015 (.38)
1500	call for info	.002 (.05)	.007 (.18)	.012 (.30)

For pressures greater than 1500 psi consult Freudenberg-NOK Sealing Technologies.

OTHER GROOVE DETAILS

In addition to proper compression and gland fill, a properly designed and machined gland is essential for a good O-ring seal. The tables at the right and the diagram below provide the recommended gland design parameters. In addition, the gland surfaces must be free from all machining irregularities, and the gland edges should be smooth and true and free of nicks, scratches, and burrs.

Detail	Inch	Millimeter
Wall angle	0° to 5°	0° to 5°
Break edge	.005 to .010	.13 to .25
Static sealing Surface finish	32 μinch maximum	0.8 μm maximum
Static contain Surface finish	64 μinch maximum	1.6 μm maximum
Radius	See table below	

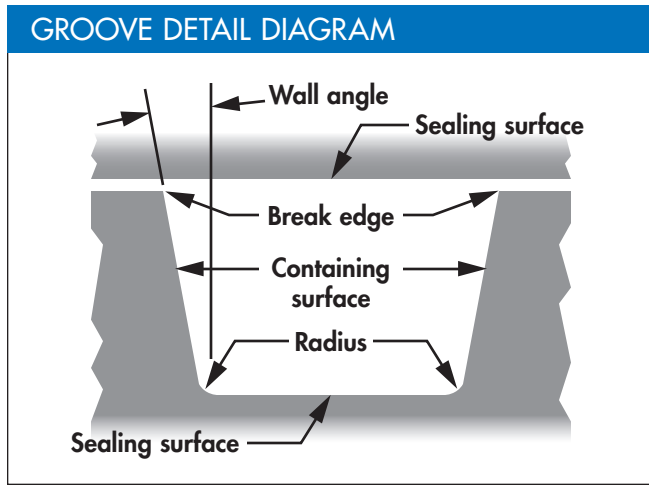

AS568 Series	Radius (inch)		Radius (mm)	
	Min.	Max.	Min.	Max.
-0XX	.005	.015	.13	.38
-1XX	.005	.015	.13	.38
-2XX	.010	.025	.25	.64
-3XX	.020	.035	.51	.89
-4XX	.020	.035	.51	.89

INSTALLATION AIDS

A perfectly designed O-ring seal is of little use if the O-ring is damaged during installation. To prevent installation damage for piston-type and rod-type seals, we recommend a 15° chamfer on the bore or rod. The chamfer must be

long enough to ensure that the O-ring sees only the chamfer when it is installed. Face-type seals do not require design considerations beyond the groove detail recommendations offered above.

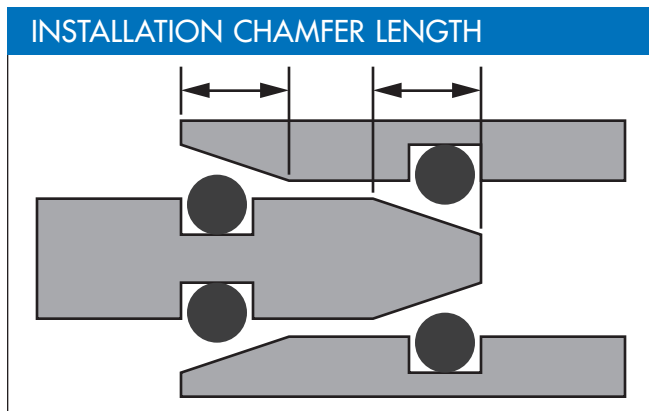

AS568 Series	O-Ring CS		Chamfer Length	
	inches	mm	inches	mm
-0XX	.070	1.78	.083	2.10
-1XX	.103	2.62	.122	3.10
-2XX	.139	3.53	.157	4.00
-3XX	.210	5.33	.236	6.00
-4XX	.275	6.99	.283	7.20
-4XX	.020	.035	.51	.89

PROPERTIES OF COMMONLY USED ELASTOMERS

Material Name	Simriz®	Super FKM	Aflas®	Fluoro-carbon	Ethylene Propylene	Nitrile	Silicone	Fluoro-silicone
ASTM D1418 Designation	FFKM	ETP	TFE/P	FKM	EPDM	NBR	VMQ	FVMQ
TYPICAL COLORS								
	Black	Black	Black	Black	Black	Black	Red	Blue
	White	White		White	Purple		White	
	Clear			Brown				
				Green				
OPERATING TEMPERATURE RANGE								
Low Temperature	-20°C	-20°C	-10°C	-40°C	-55°C	-50°C	-75°C	-65°C
	-4°F	-4°F	+14°F	-40°F	-67°F	-58°F	-103°F	-85°F
High Temperature	300°C	200°C	200°C	250°C	150°C	120°C	230°C	180°C
	572°F	392°F	392°F	482°F	302°F	248°F	446°F	356°F
PHYSICAL PROPERTIES								
Abrasion Resistance	3	2	2	2	1	2	4	4
Permeation Resistance	2	2	2	1	2	2	4	4
Compression Set Resistance	2	2	2	1	2	1	1	1
Tear Resistance	3	3	3	3	1	2	4	4
CHEMICAL COMPATIBILITY								
INORGANIC								
Acids	1	1	1	1	1	2	3	2
Bases	1	2	1	4	1	2	3	3
ORGANIC								
Acids	1	1	1	1	1	2	3	2
Alcohols	1	1	1	3	1	1	1	1
Aldehydes	1	2	4	3	1	3	2	4
Amines	2	2	1	4	1	4	2	4
Aromatic Hydrocarbons	1	1	4	1	4	3	4	1
Ether	1	3	4	4	3	4	4	3
Halogenides	2	1	4	1	4	4	4	4
Ketone	1	3	4	4	1	4	4	4
Water	1	1	1	1	1	1	1	1
Steam (<149°C/300°F)	1	2	2	2	1	4	3	4
Steam (>149°C/300°F)	2	3	3	4	4	4	4	4

Material rating: **1]** Little or no effect (Volume swell <10%) **2]** Possible loss of physical properties (Volume swell 10–20%)
3] Noticeable change (Volume swell 20–40%) **4]** Excessive change (>40%). Not suitable for service **0]** Insufficient information

ELASTOMER MATERIALS

SIMRIZ® PERFLUOROELASTOMER

Designation: FFKM

Description: Excellent resistance to all chemicals. Excellent outgassing performance in vacuum environments.

Limitations: Avoid low-molecular-weight, fully halogenated fluids and molten alkali metals. Strong oxidizing acids may cause some swelling. Poor compression set may not be suitable for some applications. Helium permeability is slightly higher than fluoroelastomer compounds. Specific **Simriz** compounds provide better low-temperature performance and amine resistance.

Temperature Range: -20° to 300°C (-4° to 572°F)

HIGHLY FLUORINATED FLUOROELASTOMERS

Designation: ETP (Viton®)

Description: Excellent resistance to most chemicals. The performance of these products is greater than traditional fluoroelastomers.

Limitations: Contamination performance is somewhat less than Simriz perfluoroelastomer. Avoid service in strong bases or amines.

Temperature Range: -20° to 200°C (-4° to 392°F)

TETRAFLUOROETHYLENE/PROPYLENE ELASTOMERS

Designation: TFE/P (Aflas®)

Description: Fluorocarbon elastomer noted for exceptional thermal and chemical resistance. Excellent resistance to acids, bases, water, and amines. Widely used in oil fields.

Limitations: Avoid polar solvents and aromatic fuels. Compression set performance may be too high for some applications.

Temperature Range: -10° to 200°C (14° to 400°F)

Viton® is a registered trademarks of DuPont.
Aflas® is a registered trademark of Asahi Glass Co.

STANDARD FLUROELASTOMERS

Designation: FKM

Description: Excellent resistance to petroleum products and solvents. Very good high-temperature performance. Fluorocarbon elastomers make up the most widely used seals in the semiconductor industry.

Limitations: Avoid polar solvents, amines, anhydrous ammonia, SKYDROL, hydrazine, and hot acids.

Temperature Range: -40° to 200°C (-40° to 392°F)

HYDROCARBON ELASTOMERS—ETHYLENE-PROPYLENE

Designation: EP, EPDM

Description: Excellent resistance to water, steam, and polar solvents, as well as ozone and sunlight. Also resistant to alcohols, glycol engine coolants, and SKYDROL (phosphate ester hydraulic fluid). Divided into sulphur-cured and peroxide-cured types. Peroxide-cured compounds are suitable for higher temperatures and have much lower compression sets.

Limitations: Avoid non-polar solvents, petroleum oils, and aromatic fuels.

Temperature Range: -55° to 150°C (-67° to 302°F)

HYDROCARBON ELASTOMERS—NITRILE

Designation: NBR, XNBR, HNBR

Description: Very commonly used for O-rings because of its good mechanical properties and low cost. Standard Nitrile is also known as Buna-N. Excellent resistance to petroleum-based oils and fuels, water and alcohols. Nitrile also has good resistance to acids and bases, except those with a strong oxidizing effect. HNBR is obtained by partially or fully hydrogenating NBR leading to considerable improvement of the resistance to heat, ozone, and aging.

Limitations: Avoid highly polar solvents (Acetone, MEK, etc.) and direct exposure to ozone and sunlight.

Temperature Range: -55° to 120°C (-65° to 248°F)

ELASTOMER MATERIALS

SILICONE ELASTOMERS—SILICONE

Designation: MQ, PMQ, VMQ, PVMQ

Description: Excellent material for static service at extreme (hot or cold) temperatures. Outstanding flex and fatigue life. Very good for ozone and UV radiation service as well as for resistance to fungal and biological attack.

Limitations: Avoid chlorinated solvents, aliphatic and aromatic hydrocarbons and petroleum oils. Silicones are generally very permeable to gases and have poor physical strength and abrasion resistance.

Temperature Range: -115° to 232°C (-175° to 450°F)

FLUROSILICONE ELASTOMERS— FLUROSILICONE

Designation: FVMQ

Description: Combines excellent low-temperature performance of silicone with improved chemical resistance. Very good resistance to military and aerospace fuels. Excellent performance in oxygen plasma environments.

Limitations: Avoid polar solvents, hydrocarbon fluids and phosphate ester brake fluids. Susceptible to hydrolysis by acids and bases. Limited abrasion resistance.

Temperature Range: -60° to 180°C (-76° to 356°F)

PERFLUOROETHER

Designation: FFO

Description: Combines low-temperature flexibility, fuel resistance, oil resistance, high-temperature stability, and phosphate ester fluid resistance. Excellent performance in jet fuel, piston and jet engine lubricants, and all types of aircraft hydraulic systems.

Limitations: Avoid ketone solvents.

Temperature Range: -65° to 200°C (-85°F to 392°F)

COMPARATIVE TEMPERATURE/CHEMICAL RESISTANCE LIMITS

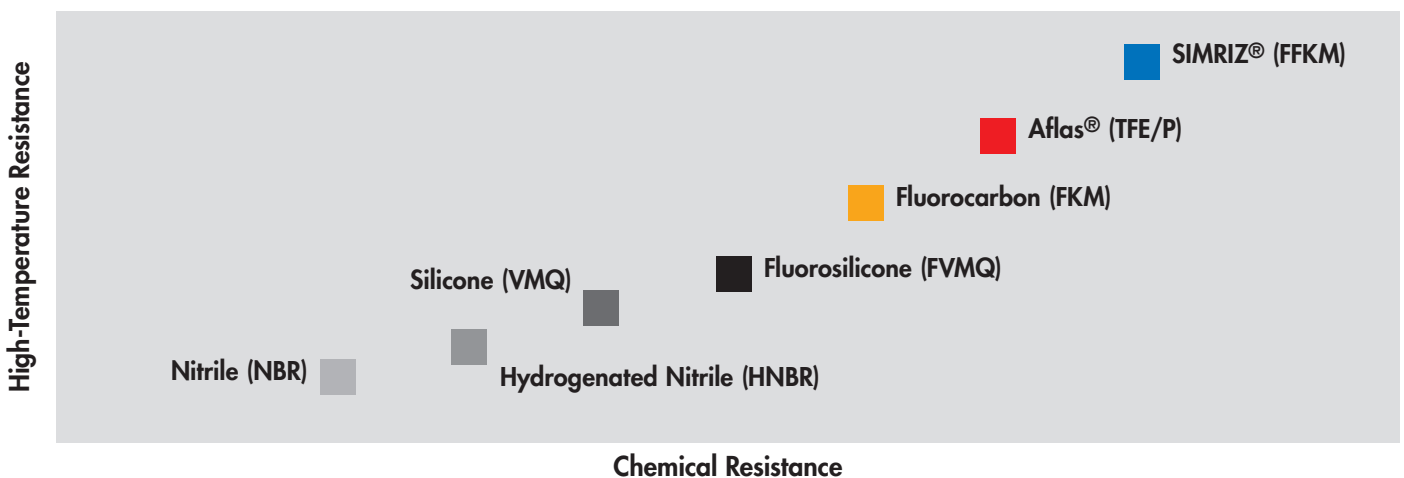

SIX SIGMA QUALITY

Freudenberg–NOK Sealing Technologies O-rings often exceed Six Sigma levels of quality. By optimizing material and manufacturing processes, Freudenberg–NOK Sealing Technologies ensures the highest quality output with virtually no manufacturing imperfections. Automated vision systems are often used to double-check characteristics which are imperceptible to the human eye, with the goal of producing better than Six Sigma Quality.

What is Six Sigma?

Motorola pioneered the notion of Six Sigma Quality as a way to improve processes and decrease defect levels. A process capability index (Cp) is used to measure the relationship between the measured values of a statistical sample and the specified tolerance range. A process with a Cp of 1.00 will use the entire allowable tolerance. This is known as Three Sigma Quality. Six Sigma Quality stresses refining of the process to achieve a Cp of 2.00. As an example of industry standards, the Aerospace O-ring industry is currently operating at about 1.33 Cp for dimensional conformance, with the next target being a 1.67 Cp.

PRACTICAL IMPACT OF LONG-TERM PROCESS CAPABILITY

SIGMA	Defects per million parts (DPM)	Cost of poor quality
SIX	3.4 DPM	<10% of sales (World class)
FIVE	233 DPM	10–15% of sales
FOUR	6,210 DPM	15–20% of sales (Industry average)
THREE	66,807 DPM	20–30% of sales
TWO	308,537 DPM	30–40% of sales (Noncompetitive)
ONE	690,000 DPM	Prohibitive loss of sales

The following chart is a literal interpretation of the comparative significance of Sigma Quality levels.

Sigma Level	Wasted Space	Lost Time	Spell Check
Three Sigma	Floor space of a small retail store	3½ months in a century	1–2 misspelled words per page in a book
Four Sigma	Floor space of a typical living room	3½ days in a century	1 misspelled word per 30 pages in a book
Five Sigma	Surface area of a typical computer tablet	30 minutes in a century	1 misspelled word in all the books on a bookshelf
Six Sigma	The size of a computer chip	6 seconds in a century	1 misspelled word in all the books in a small library

AS568 DIMENSIONS

AS568 is the Aerospace Size Standard for O-rings from the Society of Automotive Engineers. Simrit manufactures and supplies the complete range of standard AS568 sizes in a wide range of elastomeric O-ring materials. The following sizes are grouped by cross-section and listed numerically by inside diameter.

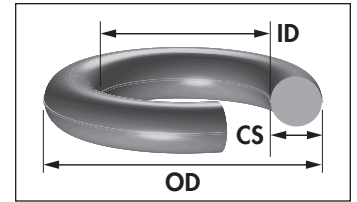

AS568 SIZE	Nominal (refer.)		Measurements in inches				Measurements in millimeters				AS568 SIZE
	ID	CS	ID	±	CS	±	ID	±	CS	±	
-001	1/32	1/32	0.029	0.004	0.040	0.003	0.74	0.10	1.02	0.08	-001
-002	3/64	3/64	0.042	0.004	0.050	0.003	1.07	0.10	1.27	0.08	-002
-003	1/16	1/16	0.056	0.004	0.060	0.003	1.42	0.10	1.52	0.08	-003
-004	5/64	1/16	0.070	0.005	0.070	0.003	1.78	0.13	1.78	0.08	-004
-005	3/32	1/16	0.101	0.005	0.070	0.003	2.57	0.13	1.78	0.08	-005
-006	1/8	1/16	0.114	0.005	0.070	0.003	2.90	0.13	1.78	0.08	-006
-007	5/32	1/16	0.145	0.005	0.070	0.003	3.68	0.13	1.78	0.08	-007
-008	3/16	1/16	0.176	0.005	0.070	0.003	4.47	0.13	1.78	0.08	-008
-009	7/32	1/16	0.208	0.005	0.070	0.003	5.28	0.13	1.78	0.08	-009
-010	1/4	1/16	0.239	0.005	0.070	0.003	6.07	0.13	1.78	0.08	-010
-011	5/16	1/16	0.301	0.005	0.070	0.003	7.65	0.13	1.78	0.08	-011
-012	3/8	1/16	0.364	0.005	0.070	0.003	9.25	0.13	1.78	0.08	-012
-013	7/16	1/16	0.426	0.005	0.070	0.003	10.82	0.13	1.78	0.08	-013
-014	1/2	1/16	0.489	0.005	0.070	0.003	12.42	0.13	1.78	0.08	-014
-015	9/16	1/16	0.551	0.007	0.070	0.003	14.00	0.18	1.78	0.08	-015
-016	5/8	1/16	0.614	0.009	0.070	0.003	15.60	0.23	1.78	0.08	-016
-017	11/16	1/16	0.676	0.009	0.070	0.003	17.17	0.23	1.78	0.08	-017
-018	3/4	1/16	0.739	0.009	0.070	0.003	18.77	0.23	1.78	0.08	-018
-019	13/16	1/16	0.801	0.009	0.070	0.003	20.35	0.23	1.78	0.08	-019
-020	7/8	1/16	0.864	0.009	0.070	0.003	21.95	0.23	1.78	0.08	-020
-021	15/16	1/16	0.926	0.009	0.070	0.003	23.52	0.23	1.78	0.08	-021
-022	1	1/16	0.989	0.010	0.070	0.003	25.12	0.25	1.78	0.08	-022
-023	1 1/16	1/16	1.051	0.010	0.070	0.003	26.70	0.25	1.78	0.08	-023
-024	1 1/8	1/16	1.114	0.010	0.070	0.003	28.30	0.25	1.78	0.08	-024
-025	1 3/16	1/16	1.176	0.011	0.070	0.003	29.87	0.28	1.78	0.08	-025
-026	1 1/4	1/16	1.239	0.011	0.070	0.003	31.47	0.28	1.78	0.08	-026
-027	1 5/16	1/16	1.301	0.011	0.070	0.003	33.05	0.28	1.78	0.08	-027
-028	1 3/8	1/16	1.364	0.013	0.070	0.003	34.65	0.33	1.78	0.08	-028
-029	1 1/2	1/16	1.489	0.013	0.070	0.003	37.82	0.33	1.78	0.08	-029
-030	1 5/8	1/16	1.614	0.013	0.070	0.003	41.00	0.33	1.78	0.08	-030
-031	1 3/4	1/16	1.739	0.015	0.070	0.003	44.17	0.38	1.78	0.08	-031
-032	1 7/8	1/16	1.864	0.015	0.070	0.003	47.35	0.38	1.78	0.08	-032
-033	2	1/16	1.989	0.018	0.070	0.003	50.52	0.46	1.78	0.08	-033
-034	2 1/8	1/16	2.114	0.018	0.070	0.003	53.70	0.46	1.78	0.08	-034
-035	2 1/4	1/16	2.239	0.018	0.070	0.003	56.87	0.46	1.78	0.08	-035
-036	2 3/8	1/16	2.364	0.018	0.070	0.003	60.05	0.46	1.78	0.08	-036
-037	2 1/2	1/16	2.489	0.018	0.070	0.003	63.22	0.46	1.78	0.08	-037
-038	2 5/8	1/16	2.614	0.020	0.070	0.003	66.40	0.51	1.78	0.08	-038
-039	2 3/4	1/16	2.739	0.020	0.070	0.003	69.57	0.51	1.78	0.08	-039

AS568 DIMENSIONS

AS568 is the Aerospace Size Standard for O-rings from the Society of Automotive Engineers. Simrit manufactures and supplies the complete range of standard AS568 sizes in a wide range of elastomeric O-ring materials. The following sizes are grouped by cross-section and listed numerically by inside diameter.

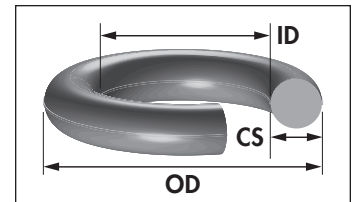

AS568 SIZE	Nominal (refer.)		Measurements in inches				Measurements in millimeters				AS568 SIZE
	ID	CS	ID	±	CS	±	ID	±	CS	±	
-040	2 7/8	1/16	2.864	0.020	0.070	0.003	72.75	0.51	1.78	0.08	-040
-041	3	1/16	2.989	0.024	0.070	0.003	75.92	0.61	1.78	0.08	-041
-042	3 1/4	1/16	3.239	0.024	0.070	0.003	82.27	0.61	1.78	0.08	-042
-043	3 1/2	1/16	3.489	0.024	0.070	0.003	88.62	0.61	1.78	0.08	-043
-044	3 3/4	1/16	3.739	0.027	0.070	0.003	94.97	0.69	1.78	0.08	-044
-045	4	1/16	3.989	0.027	0.070	0.003	101.32	0.69	1.78	0.08	-045
-046	4 1/4	1/16	4.239	0.030	0.070	0.003	107.67	0.76	1.78	0.08	-046
-047	4 1/2	1/16	4.489	0.030	0.070	0.003	114.02	0.76	1.78	0.08	-047
-048	4 3/4	1/16	4.739	0.030	0.070	0.003	120.37	0.76	1.78	0.08	-048
-049	5	1/16	4.989	0.037	0.070	0.003	126.72	0.94	1.78	0.08	-049
-050	5 1/4	1/16	5.239	0.037	0.070	0.003	133.07	0.94	1.78	0.08	-050

AS568 DIMENSIONS

AS568 is the Aerospace Size Standard for O-rings from the Society of Automotive Engineers. Simrit manufactures and supplies the complete range of standard AS568 sizes in a wide range of elastomeric O-ring materials. The following sizes are grouped by cross-section and listed numerically by inside diameter.

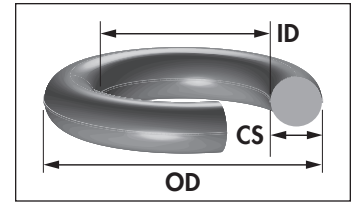

AS568 SIZE	Nominal (refer.)		Measurements in inches				Measurements in millimeters				AS568 SIZE
	ID	CS	ID	±	CS	±	ID	±	CS	±	
-102	1/16	3/32	0.049	0.005	0.103	0.003	1.24	0.13	2.62	0.08	-102
-103	3/32	3/32	0.081	0.005	0.103	0.003	2.06	0.13	2.62	0.08	-103
-104	1/8	3/32	0.112	0.005	0.103	0.003	2.84	0.13	2.62	0.08	-104
-105	5/32	3/32	0.143	0.005	0.103	0.003	3.63	0.13	2.62	0.08	-105
-106	3/16	3/32	0.174	0.005	0.103	0.003	4.42	0.13	2.62	0.08	-106
-107	7/32	3/32	0.206	0.005	0.103	0.003	5.23	0.13	2.62	0.08	-107
-108	1/4	3/32	0.237	0.005	0.103	0.003	6.02	0.13	2.62	0.08	-108
-109	5/16	3/32	0.299	0.005	0.103	0.003	7.59	0.13	2.62	0.08	-109
-110	3/8	3/32	0.362	0.005	0.103	0.003	9.19	0.13	2.62	0.08	-110
-111	7/16	3/32	0.424	0.005	0.103	0.003	10.77	0.13	2.62	0.08	-111
-112	1/2	3/32	0.487	0.005	0.103	0.003	12.37	0.13	2.62	0.08	-112
-113	9/16	3/32	0.549	0.007	0.103	0.003	13.94	0.18	2.62	0.08	-113
-114	5/8	3/32	0.612	0.009	0.103	0.003	15.54	0.23	2.62	0.08	-114
-115	11/16	3/32	0.674	0.009	0.103	0.003	17.12	0.23	2.62	0.08	-115
-116	3/4	3/32	0.737	0.009	0.103	0.003	18.72	0.23	2.62	0.08	-116
-117	13/16	3/32	0.799	0.010	0.103	0.003	20.29	0.25	2.62	0.08	-117
-118	7/8	3/32	0.862	0.010	0.103	0.003	21.89	0.25	2.62	0.08	-118
-119	15/16	3/32	0.924	0.010	0.103	0.003	23.47	0.25	2.62	0.08	-119
-120	1	3/32	0.987	0.010	0.103	0.003	25.07	0.25	2.62	0.08	-120
-121	1 1/16	3/32	1.049	0.010	0.103	0.003	26.64	0.25	2.62	0.08	-121
-122	1 1/8	3/32	1.112	0.010	0.103	0.003	28.24	0.25	2.62	0.08	-122
-123	1 3/16	3/32	1.174	0.012	0.103	0.003	29.82	0.30	2.62	0.08	-123
-124	1 1/4	3/32	1.237	0.012	0.103	0.003	31.42	0.30	2.62	0.08	-124
-125	1 5/16	3/32	1.299	0.012	0.103	0.003	32.99	0.30	2.62	0.08	-125
-126	1 3/8	3/32	1.362	0.012	0.103	0.003	34.59	0.30	2.62	0.08	-126
-127	1 7/16	3/32	1.424	0.012	0.103	0.003	36.17	0.30	2.62	0.08	-127
-128	1 1/2	3/32	1.487	0.012	0.103	0.003	37.77	0.30	2.62	0.08	-128
-129	1 9/16	3/32	1.549	0.015	0.103	0.003	39.34	0.38	2.62	0.08	-129
-130	1 5/8	3/32	1.612	0.015	0.103	0.003	40.94	0.38	2.62	0.08	-130
-131	1 11/16	3/32	1.674	0.015	0.103	0.003	42.52	0.38	2.62	0.08	-131
-132	1 3/4	3/32	1.737	0.015	0.103	0.003	44.12	0.38	2.62	0.08	-132
-133	1 13/16	3/32	1.799	0.015	0.103	0.003	45.69	0.38	2.62	0.08	-133
-134	1 7/8	3/32	1.862	0.015	0.103	0.003	47.29	0.38	2.62	0.08	-134
-135	1 15/16	3/32	1.925	0.017	0.103	0.003	48.90	0.43	2.62	0.08	-135
-136	2	3/32	1.987	0.017	0.103	0.003	50.47	0.43	2.62	0.08	-136
-137	2 1/16	3/32	2.050	0.017	0.103	0.003	52.07	0.43	2.62	0.08	-137
-138	2 1/8	3/32	2.112	0.017	0.103	0.003	53.64	0.43	2.62	0.08	-138
-139	2 3/16	3/32	2.175	0.017	0.103	0.003	55.25	0.43	2.62	0.08	-139

AS568 DIMENSIONS

AS568 is the Aerospace Size Standard for O-rings from the Society of Automotive Engineers. Simrit manufactures and supplies the complete range of standard AS568 sizes in a wide range of elastomeric O-ring materials. The following sizes are grouped by cross-section and listed numerically by inside diameter.

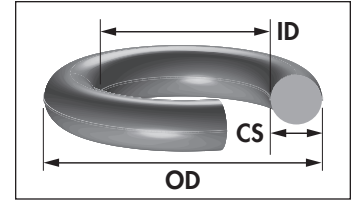

AS568 SIZE	Nominal (refer.)		Measurements in inches				Measurements in millimeters				AS568 SIZE
	ID	CS	ID	±	CS	±	ID	±	CS	±	
-140	2 1/4	3/32	2.237	0.017	0.103	0.003	56.82	0.43	2.62	0.08	-140
-141	2 5/16	3/32	2.300	0.020	0.103	0.003	58.42	0.51	2.62	0.08	-141
-142	2 3/8	3/32	2.362	0.020	0.103	0.003	59.99	0.51	2.62	0.08	-142
-143	2 7/16	3/32	2.425	0.020	0.103	0.003	61.60	0.51	2.62	0.08	-143
-144	2 1/2	3/32	2.487	0.020	0.103	0.003	63.17	0.51	2.62	0.08	-144
-145	2 9/16	3/32	2.550	0.020	0.103	0.003	64.77	0.51	2.62	0.08	-145
-146	2 5/8	3/32	2.612	0.020	0.103	0.003	66.34	0.51	2.62	0.08	-146
-147	2 11/16	3/32	2.675	0.022	0.103	0.003	67.95	0.56	2.62	0.08	-147
-148	2 3/4	3/32	2.737	0.022	0.103	0.003	69.52	0.56	2.62	0.08	-148
-149	2 13/16	3/32	2.800	0.022	0.103	0.003	71.12	0.56	2.62	0.08	-149
-150	2 7/8	3/32	2.862	0.022	0.103	0.003	72.69	0.56	2.62	0.08	-150
-151	3	3/32	2.987	0.024	0.103	0.003	75.87	0.61	2.62	0.08	-151
-152	3 1/4	3/32	3.237	0.024	0.103	0.003	82.22	0.61	2.62	0.08	-152
-153	3 1/2	3/32	3.487	0.024	0.103	0.003	88.57	0.61	2.62	0.08	-153
-154	3 3/4	3/32	3.737	0.028	0.103	0.003	94.92	0.71	2.62	0.08	-154
-155	4	3/32	3.987	0.028	0.103	0.003	101.27	0.71	2.62	0.08	-155
-156	4 1/4	3/32	4.237	0.030	0.103	0.003	107.62	0.76	2.62	0.08	-156
-157	4 1/2	3/32	4.487	0.030	0.103	0.003	113.97	0.76	2.62	0.08	-157
-158	4 3/4	3/32	4.737	0.030	0.103	0.003	120.32	0.76	2.62	0.08	-158
-159	5	3/32	4.987	0.035	0.103	0.003	126.67	0.89	2.62	0.08	-159
-160	5 1/4	3/32	5.237	0.035	0.103	0.003	133.02	0.89	2.62	0.08	-160
-161	5 1/2	3/32	5.487	0.035	0.103	0.003	139.37	0.89	2.62	0.08	-161
-162	5 3/4	3/32	5.737	0.035	0.103	0.003	145.72	0.89	2.62	0.08	-162
-163	6	3/32	5.987	0.035	0.103	0.003	152.07	0.89	2.62	0.08	-163
-164	6 1/4	3/32	6.237	0.040	0.103	0.003	158.42	1.02	2.62	0.08	-164
-165	6 1/2	3/32	6.487	0.040	0.103	0.003	164.77	1.02	2.62	0.08	-165
-166	6 3/4	3/32	6.737	0.040	0.103	0.003	171.12	1.02	2.62	0.08	-166
-167	7	3/32	6.987	0.040	0.103	0.003	177.47	1.02	2.62	0.08	-167
-168	7 1/4	3/32	7.237	0.045	0.103	0.003	183.82	1.14	2.62	0.08	-168
-169	7 1/2	3/32	7.487	0.045	0.103	0.003	190.17	1.14	2.62	0.08	-169
-170	7 3/4	3/32	7.737	0.045	0.103	0.003	196.52	1.14	2.62	0.08	-170
-171	8	3/32	7.987	0.045	0.103	0.003	202.87	1.14	2.62	0.08	-171
-172	8 1/4	3/32	8.237	0.050	0.103	0.003	209.22	1.27	2.62	0.08	-172
-173	8 1/2	3/32	8.487	0.050	0.103	0.003	215.57	1.27	2.62	0.08	-173
-174	8 3/4	3/32	8.737	0.050	0.103	0.003	221.92	1.27	2.62	0.08	-174
-175	9	3/32	8.987	0.050	0.103	0.003	228.27	1.27	2.62	0.08	-175
-176	9 1/4	3/32	9.237	0.055	0.103	0.003	234.62	1.40	2.62	0.08	-176
-177	9 1/2	3/32	9.487	0.055	0.103	0.003	240.97	1.40	2.62	0.08	-177
-178	9 3/4	3/32	9.737	0.055	0.103	0.003	247.32	1.40	2.62	0.08	-178

AS568 DIMENSIONS

AS568 is the Aerospace Size Standard for O-rings from the Society of Automotive Engineers. Simrit manufactures and supplies the complete range of standard AS568 sizes in a wide range of elastomeric O-ring materials. The following sizes are grouped by cross-section and listed numerically by inside diameter.

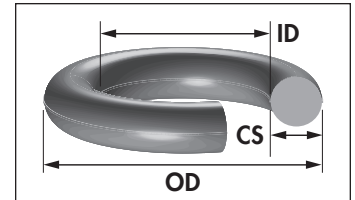

AS568 SIZE	Nominal (refer.)		Measurements in inches				Measurements in millimeters				AS568 SIZE
	ID	CS	ID	±	CS	±	ID	±	CS	±	
-201	3/16	1/8	0.171	0.005	0.139	0.004	4.34	0.13	3.53	0.10	-201
-202	1/4	1/8	0.234	0.005	0.139	0.004	5.94	0.13	3.53	0.10	-202
-203	5/16	1/8	0.296	0.005	0.139	0.004	7.52	0.13	3.53	0.10	-203
-204	3/8	1/8	0.359	0.005	0.139	0.004	9.12	0.13	3.53	0.10	-204
-205	7/16	1/8	0.421	0.005	0.139	0.004	10.69	0.13	3.53	0.10	-205
-206	1/2	1/8	0.484	0.005	0.139	0.004	12.29	0.13	3.53	0.10	-206
-207	9/16	1/8	0.546	0.007	0.139	0.004	13.87	0.18	3.53	0.10	-207
-208	5/8	1/8	0.609	0.009	0.139	0.004	15.47	0.23	3.53	0.10	-208
-209	11/16	1/8	0.671	0.009	0.139	0.004	17.04	0.23	3.53	0.10	-209
-210	3/4	1/8	0.734	0.010	0.139	0.004	18.64	0.25	3.53	0.10	-210
-211	13/16	1/8	0.796	0.010	0.139	0.004	20.22	0.25	3.53	0.10	-211
-212	7/8	1/8	0.859	0.010	0.139	0.004	21.82	0.25	3.53	0.10	-212
-213	15/16	1/8	0.921	0.010	0.139	0.004	23.39	0.25	3.53	0.10	-213
-214	1	1/8	0.984	0.010	0.139	0.004	24.99	0.25	3.53	0.10	-214
-215	1 1/16	1/8	1.046	0.010	0.139	0.004	26.57	0.25	3.53	0.10	-215
-216	1 1/8	1/8	1.109	0.012	0.139	0.004	28.17	0.30	3.53	0.10	-216
-217	1 3/16	1/8	1.171	0.012	0.139	0.004	29.74	0.30	3.53	0.10	-217
-218	1 1/4	1/8	1.234	0.012	0.139	0.004	31.34	0.30	3.53	0.10	-218
-219	1 5/16	1/8	1.296	0.012	0.139	0.004	32.92	0.30	3.53	0.10	-219
-220	1 3/8	1/8	1.359	0.012	0.139	0.004	34.52	0.30	3.53	0.10	-220
-221	1 7/16	1/8	1.421	0.012	0.139	0.004	36.09	0.30	3.53	0.10	-221
-222	1 1/2	1/8	1.484	0.015	0.139	0.004	37.69	0.38	3.53	0.10	-222
-223	1 5/8	1/8	1.609	0.015	0.139	0.004	40.87	0.38	3.53	0.10	-223
-224	1 3/4	1/8	1.734	0.015	0.139	0.004	44.04	0.38	3.53	0.10	-224
-225	1 7/8	1/8	1.859	0.018	0.139	0.004	47.22	0.46	3.53	0.10	-225
-226	2	1/8	1.984	0.018	0.139	0.004	50.39	0.46	3.53	0.10	-226
-227	2 1/8	1/8	2.109	0.018	0.139	0.004	53.57	0.46	3.53	0.10	-227
-228	2 1/4	1/8	2.234	0.020	0.139	0.004	56.74	0.51	3.53	0.10	-228
-229	2 3/8	1/8	2.359	0.020	0.139	0.004	59.92	0.51	3.53	0.10	-229
-230	2 1/2	1/8	2.484	0.020	0.139	0.004	63.09	0.51	3.53	0.10	-230
-231	2 5/8	1/8	2.609	0.020	0.139	0.004	66.27	0.51	3.53	0.10	-231
-232	2 3/4	1/8	2.734	0.024	0.139	0.004	69.44	0.61	3.53	0.10	-232
-233	2 7/8	1/8	2.859	0.024	0.139	0.004	72.62	0.61	3.53	0.10	-233
-234	3	1/8	2.984	0.024	0.139	0.004	75.79	0.61	3.53	0.10	-234
-235	3 1/8	1/8	3.109	0.024	0.139	0.004	78.97	0.61	3.53	0.10	-235
-236	3 1/4	1/8	3.234	0.024	0.139	0.004	82.14	0.61	3.53	0.10	-236
-237	3 3/8	1/8	3.359	0.024	0.139	0.004	85.32	0.61	3.53	0.10	-237
-238	3 1/2	1/8	3.484	0.024	0.139	0.004	88.49	0.61	3.53	0.10	-238
-239	3 5/8	1/8	3.609	0.028	0.139	0.004	91.67	0.71	3.53	0.10	-239

AS568 DIMENSIONS

AS568 is the Aerospace Size Standard for O-rings from the Society of Automotive Engineers. Simrit manufactures and supplies the complete range of standard AS568 sizes in a wide range of elastomeric O-ring materials. The following sizes are grouped by cross-section and listed numerically by inside diameter.

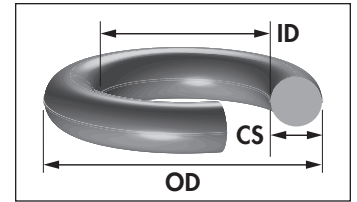

AS568 SIZE	Nominal (refer.)		Measurements in inches				Measurements in millimeters				AS568 SIZE
	ID	CS	ID	±	CS	±	ID	±	CS	±	
-240	3 3/4	1/8	3.734	0.028	0.139	0.004	94.84	0.71	3.53	0.10	-240
-241	3 7/8	1/8	3.859	0.028	0.139	0.004	98.02	0.71	3.53	0.10	-241
-242	4	1/8	3.984	0.028	0.139	0.004	101.19	0.71	3.53	0.10	-242
-243	4 1/8	1/8	4.109	0.028	0.139	0.004	104.37	0.71	3.53	0.10	-243
-244	4 1/4	1/8	4.234	0.030	0.139	0.004	107.54	0.76	3.53	0.10	-244
-245	4 3/8	1/8	4.359	0.030	0.139	0.004	110.72	0.76	3.53	0.10	-245
-246	4 1/2	1/8	4.484	0.030	0.139	0.004	113.89	0.76	3.53	0.10	-246
-247	4 5/8	1/8	4.609	0.030	0.139	0.004	117.07	0.76	3.53	0.10	-247
-248	4 3/4	1/8	4.734	0.030	0.139	0.004	120.24	0.76	3.53	0.10	-248
-249	4 7/8	1/8	4.859	0.035	0.139	0.004	123.42	0.89	3.53	0.10	-249
-250	5	1/8	4.984	0.035	0.139	0.004	126.59	0.89	3.53	0.10	-250
-251	5 1/8	1/8	5.109	0.035	0.139	0.004	129.77	0.89	3.53	0.10	-251
-252	5 1/4	1/8	5.234	0.035	0.139	0.004	132.94	0.89	3.53	0.10	-252
-253	5 3/8	1/8	5.359	0.035	0.139	0.004	136.12	0.89	3.53	0.10	-253
-254	5 1/2	1/8	5.484	0.035	0.139	0.004	139.29	0.89	3.53	0.10	-254
-255	5 5/8	1/8	5.609	0.035	0.139	0.004	142.47	0.89	3.53	0.10	-255
-256	5 3/4	1/8	5.734	0.035	0.139	0.004	145.64	0.89	3.53	0.10	-256
-257	5 7/8	1/8	5.859	0.035	0.139	0.004	148.82	0.89	3.53	0.10	-257
-258	6	1/8	5.984	0.035	0.139	0.004	151.99	0.89	3.53	0.10	-258
-259	6 1/4	1/8	6.234	0.040	0.139	0.004	158.34	1.02	3.53	0.10	-259
-260	6 1/2	1/8	6.484	0.040	0.139	0.004	164.69	1.02	3.53	0.10	-260
-261	6 3/4	1/8	6.734	0.040	0.139	0.004	171.04	1.02	3.53	0.10	-261
-262	7	1/8	6.984	0.040	0.139	0.004	177.39	1.02	3.53	0.10	-262
-263	7 1/4	1/8	7.234	0.045	0.139	0.004	183.74	1.14	3.53	0.10	-263
-264	7 1/2	1/8	7.484	0.045	0.139	0.004	190.09	1.14	3.53	0.10	-264
-265	7 3/4	1/8	7.734	0.045	0.139	0.004	196.44	1.14	3.53	0.10	-265
-266	8	1/8	7.984	0.045	0.139	0.004	202.79	1.14	3.53	0.10	-266
-267	8 1/4	1/8	8.234	0.050	0.139	0.004	209.14	1.27	3.53	0.10	-267
-268	8 1/2	1/8	8.484	0.050	0.139	0.004	215.49	1.27	3.53	0.10	-268
-269	8 3/4	1/8	8.734	0.050	0.139	0.004	221.84	1.27	3.53	0.10	-269
-270	9	1/8	8.984	0.050	0.139	0.004	228.19	1.27	3.53	0.10	-270
-271	9 1/4	1/8	9.234	0.055	0.139	0.004	234.54	1.40	3.53	0.10	-271
-272	9 1/2	1/8	9.484	0.055	0.139	0.004	240.89	1.40	3.53	0.10	-272
-273	9 3/4	1/8	9.734	0.055	0.139	0.004	247.24	1.40	3.53	0.10	-273
-274	10	1/8	9.984	0.055	0.139	0.004	253.59	1.40	3.53	0.10	-274
-275	10 1/2	1/8	10.484	0.055	0.139	0.004	266.29	1.40	3.53	0.10	-275
-276	11	1/8	10.984	0.065	0.139	0.004	278.99	1.65	3.53	0.10	-276
-277	11 1/2	1/8	11.484	0.065	0.139	0.004	291.69	1.65	3.53	0.10	-277
-278	12	1/8	11.984	0.065	0.139	0.004	304.39	1.65	3.53	0.10	-278

AS568 DIMENSIONS

AS568 is the Aerospace Size Standard for O-rings from the Society of Automotive Engineers. Simrit manufactures and supplies the complete range of standard AS568 sizes in a wide range of elastomeric O-ring materials. The following sizes are grouped by cross-section and listed numerically by inside diameter.

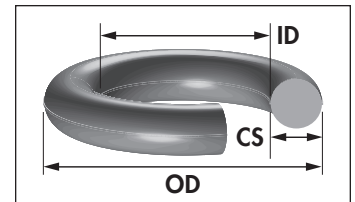

AS568 SIZE	Nominal (refer.)		Measurements in inches				Measurements in millimeters				AS568 SIZE
	ID	CS	ID	±	CS	±	ID	±	CS	±	
-279	13	1/8	12.984	0.065	0.139	0.004	329.79	1.65	3.53	0.10	-279
-280	14	1/8	13.984	0.065	0.139	0.004	355.19	1.65	3.53	0.10	-280
-281	15	1/8	14.984	0.065	0.139	0.004	380.59	1.65	3.53	0.10	-281
-282	16	1/8	15.955	0.075	0.139	0.004	405.26	1.91	3.53	0.10	-282
-283	17	1/8	16.955	0.080	0.139	0.004	430.66	2.03	3.53	0.10	-283
-284	18	1/8	17.955	0.085	0.139	0.004	456.06	2.16	3.53	0.10	-284

AS568 DIMENSIONS

AS568 is the Aerospace Size Standard for O-rings from the Society of Automotive Engineers. Simrit manufactures and supplies the complete range of standard AS568 sizes in a wide range of elastomeric O-ring materials. The following sizes are grouped by cross-section and listed numerically by inside diameter.

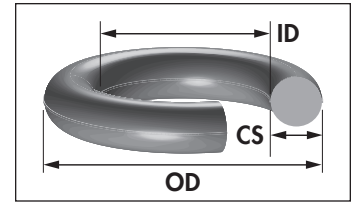

AS568 SIZE	Nominal (refer.)		Measurements in inches				Measurements in millimeters				AS568 SIZE
	ID	CS	ID	±	CS	±	ID	±	CS	±	
-309	7/16	3/16	0.412	0.005	0.210	0.005	10.46	0.13	5.33	0.13	-309
-310	1/2	3/16	0.475	0.005	0.210	0.005	12.07	0.13	5.33	0.13	-310
-311	9/16	3/16	0.537	0.007	0.210	0.005	13.64	0.18	5.33	0.13	-311
-312	5/8	3/16	0.600	0.009	0.210	0.005	15.24	0.23	5.33	0.13	-312
-313	11/16	3/16	0.662	0.009	0.210	0.005	16.81	0.23	5.33	0.13	-313
-314	3/4	3/16	0.725	0.010	0.210	0.005	18.42	0.25	5.33	0.13	-314
-315	13/16	3/16	0.787	0.010	0.210	0.005	19.99	0.25	5.33	0.13	-315
-316	7/8	3/16	0.850	0.010	0.210	0.005	21.59	0.25	5.33	0.13	-316
-317	15/16	3/16	0.912	0.010	0.210	0.005	23.16	0.25	5.33	0.13	-317
-318	1	3/16	0.975	0.010	0.210	0.005	24.77	0.25	5.33	0.13	-318
-319	1 1/16	3/16	1.037	0.010	0.210	0.005	26.34	0.25	5.33	0.13	-319
-320	1 1/8	3/16	1.100	0.012	0.210	0.005	27.94	0.30	5.33	0.13	-320
-321	1 3/16	3/16	1.162	0.012	0.210	0.005	29.51	0.30	5.33	0.13	-321
-322	1 1/4	3/16	1.225	0.012	0.210	0.005	31.12	0.30	5.33	0.13	-322
-323	1 5/16	3/16	1.287	0.012	0.210	0.005	32.69	0.30	5.33	0.13	-323
-324	1 3/8	3/16	1.350	0.012	0.210	0.005	34.29	0.30	5.33	0.13	-324
-325	1 1/2	3/16	1.475	0.015	0.210	0.005	37.47	0.38	5.33	0.13	-325
-326	1 5/8	3/16	1.600	0.015	0.210	0.005	40.64	0.38	5.33	0.13	-326
-327	1 3/4	3/16	1.725	0.015	0.210	0.005	43.82	0.38	5.33	0.13	-327
-328	1 7/8	3/16	1.850	0.015	0.210	0.005	46.99	0.38	5.33	0.13	-328
-329	2	3/16	1.975	0.018	0.210	0.005	50.17	0.46	5.33	0.13	-329
-330	2 1/8	3/16	2.100	0.018	0.210	0.005	53.34	0.46	5.33	0.13	-330
-331	2 1/4	3/16	2.225	0.018	0.210	0.005	56.52	0.46	5.33	0.13	-331
-332	2 3/8	3/16	2.350	0.018	0.210	0.005	59.69	0.46	5.33	0.13	-332
-333	2 1/2	3/16	2.475	0.020	0.210	0.005	62.87	0.51	5.33	0.13	-333
-334	2 5/8	3/16	2.600	0.020	0.210	0.005	66.04	0.51	5.33	0.13	-334
-335	2 3/4	3/16	2.725	0.020	0.210	0.005	69.22	0.51	5.33	0.13	-335
-336	2 7/8	3/16	2.850	0.020	0.210	0.005	72.39	0.51	5.33	0.13	-336
-337	3	3/16	2.975	0.024	0.210	0.005	75.57	0.61	5.33	0.13	-337
-338	3 1/8	3/16	3.100	0.024	0.210	0.005	78.74	0.61	5.33	0.13	-338
-339	3 1/4	3/16	3.225	0.024	0.210	0.005	81.92	0.61	5.33	0.13	-339
-340	3 3/8	3/16	3.350	0.024	0.210	0.005	85.09	0.61	5.33	0.13	-340
-341	3 1/2	3/16	3.475	0.024	0.210	0.005	88.27	0.61	5.33	0.13	-341
-342	3 5/8	3/16	3.600	0.028	0.210	0.005	91.44	0.71	5.33	0.13	-342
-343	3 3/4	3/16	3.725	0.028	0.210	0.005	94.62	0.71	5.33	0.13	-343
-344	3 7/8	3/16	3.850	0.028	0.210	0.005	97.79	0.71	5.33	0.13	-344
-345	4	3/16	3.975	0.028	0.210	0.005	100.97	0.71	5.33	0.13	-345
-346	4 1/8	3/16	4.100	0.028	0.210	0.005	104.14	0.71	5.33	0.13	-346
-347	4 1/4	3/16	4.225	0.030	0.210	0.005	107.32	0.76	5.33	0.13	-347

AS568 DIMENSIONS

AS568 is the Aerospace Size Standard for O-rings from the Society of Automotive Engineers. Simrit manufactures and supplies the complete range of standard AS568 sizes in a wide range of elastomeric O-ring materials. The following sizes are grouped by cross-section and listed numerically by inside diameter.

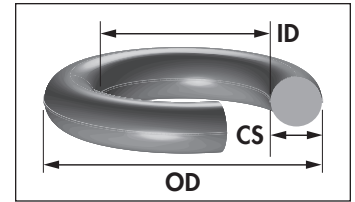

AS568 SIZE	Nominal (refer.)		Measurements in inches				Measurements in millimeters				AS568 SIZE
	ID	CS	ID	±	CS	±	ID	±	CS	±	
-348	4 3/8	3/16	4.350	0.030	0.210	0.005	110.49	0.76	5.33	0.13	-348
-349	4 1/2	3/16	4.475	0.030	0.210	0.005	113.67	0.76	5.33	0.13	-349
-350	4 5/8	3/16	4.600	0.030	0.210	0.005	116.84	0.76	5.33	0.13	-350
-351	4 3/4	3/16	4.725	0.030	0.210	0.005	120.02	0.76	5.33	0.13	-351
-352	4 7/8	3/16	4.850	0.030	0.210	0.005	123.19	0.76	5.33	0.13	-352
-353	5	3/16	4.975	0.037	0.210	0.005	126.37	0.94	5.33	0.13	-353
-354	5 1/8	3/16	5.100	0.037	0.210	0.005	129.54	0.94	5.33	0.13	-354
-355	5 1/4	3/16	5.225	0.037	0.210	0.005	132.72	0.94	5.33	0.13	-355
-356	5 3/8	3/16	5.350	0.037	0.210	0.005	135.89	0.94	5.33	0.13	-356
-357	5 1/2	3/16	5.475	0.037	0.210	0.005	139.07	0.94	5.33	0.13	-357
-358	5 5/8	3/16	5.600	0.037	0.210	0.005	142.24	0.94	5.33	0.13	-358
-359	5 3/4	3/16	5.725	0.037	0.210	0.005	145.42	0.94	5.33	0.13	-359
-360	5 7/8	3/16	5.850	0.037	0.210	0.005	148.59	0.94	5.33	0.13	-360
-361	6	3/16	5.975	0.037	0.210	0.005	151.77	0.94	5.33	0.13	-361
-362	6 1/4	3/16	6.225	0.040	0.210	0.005	158.12	1.02	5.33	0.13	-362
-363	6 1/2	3/16	6.475	0.040	0.210	0.005	164.47	1.02	5.33	0.13	-363
-364	6 3/4	3/16	6.725	0.040	0.210	0.005	170.82	1.02	5.33	0.13	-364
-365	7	3/16	6.975	0.040	0.210	0.005	177.17	1.02	5.33	0.13	-365
-366	7 1/4	3/16	7.225	0.045	0.210	0.005	183.52	1.14	5.33	0.13	-366
-367	7 1/2	3/16	7.475	0.045	0.210	0.005	189.87	1.14	5.33	0.13	-367
-368	7 3/4	3/16	7.725	0.045	0.210	0.005	196.22	1.14	5.33	0.13	-368
-369	8	3/16	7.975	0.045	0.210	0.005	202.57	1.14	5.33	0.13	-369
-370	8 1/4	3/16	8.225	0.050	0.210	0.005	208.92	1.27	5.33	0.13	-370
-371	8 1/2	3/16	8.475	0.050	0.210	0.005	215.27	1.27	5.33	0.13	-371
-372	8 3/4	3/16	8.725	0.050	0.210	0.005	221.62	1.27	5.33	0.13	-372
-373	9	3/16	8.975	0.050	0.210	0.005	227.97	1.27	5.33	0.13	-373
-374	9 1/4	3/16	9.225	0.055	0.210	0.005	234.32	1.40	5.33	0.13	-374
-375	9 1/2	3/16	9.475	0.055	0.210	0.005	240.67	1.40	5.33	0.13	-375
-376	9 3/4	3/16	9.725	0.055	0.210	0.005	247.02	1.40	5.33	0.13	-376
-377	10	3/16	9.975	0.055	0.210	0.005	253.37	1.40	5.33	0.13	-377
-378	10 1/2	3/16	10.475	0.060	0.210	0.005	266.07	1.52	5.33	0.13	-378
-379	11	3/16	10.975	0.060	0.210	0.005	278.77	1.52	5.33	0.13	-379
-380	11 1/2	3/16	11.475	0.065	0.210	0.005	291.47	1.65	5.33	0.13	-380
-381	12	3/16	11.975	0.065	0.210	0.005	304.17	1.65	5.33	0.13	-381
-382	13	3/16	12.975	0.065	0.210	0.005	329.57	1.65	5.33	0.13	-382
-383	14	3/16	13.975	0.070	0.210	0.005	354.97	1.78	5.33	0.13	-383
-384	15	3/16	14.975	0.070	0.210	0.005	380.37	1.78	5.33	0.13	-384
-385	16	3/16	15.955	0.075	0.210	0.005	405.26	1.91	5.33	0.13	-385
-386	17	3/16	16.955	0.080	0.210	0.005	430.66	2.03	5.33	0.13	-386

AS568 DIMENSIONS

AS568 is the Aerospace Size Standard for O-rings from the Society of Automotive Engineers. Simrit manufactures and supplies the complete range of standard AS568 sizes in a wide range of elastomeric O-ring materials. The following sizes are grouped by cross-section and listed numerically by inside diameter.

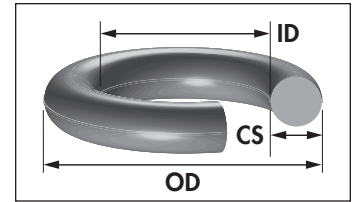

AS568 SIZE	Nominal (refer.)		Measurements in inches				Measurements in millimeters				AS568 SIZE
	ID	CS	ID	±	CS	±	ID	±	CS	±	
-387	18	3/16	17.955	0.085	0.210	0.005	456.06	2.16	5.33	0.13	-387
-388	19	3/16	18.955	0.090	0.210	0.005	481.45	2.29	5.33	0.13	-388
-389	20	3/16	19.955	0.095	0.210	0.005	506.85	2.41	5.33	0.13	-389
-390	21	3/16	20.955	0.095	0.210	0.005	532.25	2.41	5.33	0.13	-390
-391	22	3/16	21.955	0.100	0.210	0.005	557.65	2.54	5.33	0.13	-391
-392	23	3/16	22.940	0.105	0.210	0.005	582.68	2.67	5.33	0.13	-392
-393	24	3/16	23.940	0.110	0.210	0.005	608.08	2.79	5.33	0.13	-393
-394	25	3/16	24.940	0.115	0.210	0.005	633.48	2.92	5.33	0.13	-394
-395	26	3/16	25.940	0.120	0.210	0.005	658.88	3.05	5.33	0.13	-395

AS568 DIMENSIONS

AS568 is the Aerospace Size Standard for O-rings from the Society of Automotive Engineers. Simrit manufactures and supplies the complete range of standard AS568 sizes in a wide range of elastomeric O-ring materials. The following sizes are grouped by cross-section and listed numerically by inside diameter.

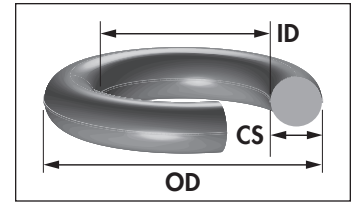

AS568 SIZE	Nominal (refer.)		Measurements in inches				Measurements in millimeters				AS568 SIZE
	ID	CS	ID	±	CS	±	ID	±	CS	±	
-425	4 1/2	1/4	4.475	0.033	0.275	0.006	113.67	0.84	6.99	0.15	-425
-426	4 5/8	1/4	4.600	0.033	0.275	0.006	116.84	0.84	6.99	0.15	-426
-427	4 3/4	1/4	4.725	0.033	0.275	0.006	120.02	0.84	6.99	0.15	-427
-428	4 7/8	1/4	4.850	0.033	0.275	0.006	123.19	0.84	6.99	0.15	-428
-429	5	1/4	4.975	0.037	0.275	0.006	126.37	0.94	6.99	0.15	-429
-430	5 1/8	1/4	5.100	0.037	0.275	0.006	129.54	0.94	6.99	0.15	-430
-431	5 1/4	1/4	5.225	0.037	0.275	0.006	132.72	0.94	6.99	0.15	-431
-432	5 3/8	1/4	5.350	0.037	0.275	0.006	135.89	0.94	6.99	0.15	-432
-433	5 1/2	1/4	5.475	0.037	0.275	0.006	139.07	0.94	6.99	0.15	-433
-434	5 5/8	1/4	5.600	0.037	0.275	0.006	142.24	0.94	6.99	0.15	-434
-435	5 3/4	1/4	5.725	0.037	0.275	0.006	145.42	0.94	6.99	0.15	-435
-436	5 7/8	1/4	5.850	0.037	0.275	0.006	148.59	0.94	6.99	0.15	-436
-437	6	1/4	5.975	0.037	0.275	0.006	151.77	0.94	6.99	0.15	-437
-438	6 1/4	1/4	6.225	0.040	0.275	0.006	158.12	1.02	6.99	0.15	-438
-439	6 1/2	1/4	6.475	0.040	0.275	0.006	164.47	1.02	6.99	0.15	-439
-440	6 3/4	1/4	6.725	0.040	0.275	0.006	170.82	1.02	6.99	0.15	-440
-441	7	1/4	6.975	0.040	0.275	0.006	177.17	1.02	6.99	0.15	-441
-442	7 1/4	1/4	7.225	0.045	0.275	0.006	183.52	1.14	6.99	0.15	-442
-443	7 1/2	1/4	7.475	0.045	0.275	0.006	189.87	1.14	6.99	0.15	-443
-444	7 3/4	1/4	7.725	0.045	0.275	0.006	196.22	1.14	6.99	0.15	-444
-445	8	1/4	7.975	0.045	0.275	0.006	202.57	1.14	6.99	0.15	-445
-446	8 1/2	1/4	8.475	0.055	0.275	0.006	215.27	1.40	6.99	0.15	-446
-447	9	1/4	8.975	0.055	0.275	0.006	227.97	1.40	6.99	0.15	-447
-448	9 1/2	1/4	9.475	0.055	0.275	0.006	240.67	1.40	6.99	0.15	-448
-449	10	1/4	9.975	0.055	0.275	0.006	253.37	1.40	6.99	0.15	-449
-450	10 1/2	1/4	10.475	0.060	0.275	0.006	266.07	1.52	6.99	0.15	-450
-451	11	1/4	10.975	0.060	0.275	0.006	278.77	1.52	6.99	0.15	-451
-452	11 1/2	1/4	11.475	0.060	0.275	0.006	291.47	1.52	6.99	0.15	-452
-453	12	1/4	11.975	0.060	0.275	0.006	304.17	1.52	6.99	0.15	-453
-454	12 1/2	1/4	12.475	0.060	0.275	0.006	316.87	1.52	6.99	0.15	-454
-455	13	1/4	12.975	0.060	0.275	0.006	329.57	1.52	6.99	0.15	-455
-456	13 1/2	1/4	13.475	0.070	0.275	0.006	342.27	1.78	6.99	0.15	-456
-457	14	1/4	13.975	0.070	0.275	0.006	354.97	1.78	6.99	0.15	-457
-458	14 1/2	1/4	14.475	0.070	0.275	0.006	367.67	1.78	6.99	0.15	-458
-459	15	1/4	14.975	0.070	0.275	0.006	380.37	1.78	6.99	0.15	-459
-460	15 1/2	1/4	15.475	0.070	0.275	0.006	393.07	1.78	6.99	0.15	-460
-461	16	1/4	15.955	0.075	0.275	0.006	405.26	1.91	6.99	0.15	-461
-462	16 1/2	1/4	16.455	0.075	0.275	0.006	417.96	1.91	6.99	0.15	-462
-463	17	1/4	16.955	0.080	0.275	0.006	430.66	2.03	6.99	0.15	-463

AS568 DIMENSIONS

AS568 is the Aerospace Size Standard for O-rings from the Society of Automotive Engineers. Simrit manufactures and supplies the complete range of standard AS568 sizes in a wide range of elastomeric O-ring materials. The following sizes are grouped by cross-section and listed numerically by inside diameter.

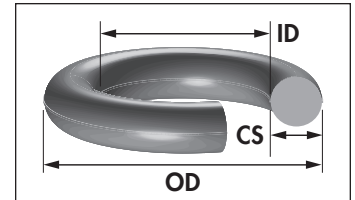

AS568 SIZE	Nominal (refer.)		Measurements in inches				Measurements in millimeters				AS568 SIZE
	ID	CS	ID	±	CS	±	ID	±	CS	±	
-464	17 1/2	1/4	17.455	0.085	0.275	0.006	443.36	2.16	6.99	0.15	-464
-465	18	1/4	17.955	0.085	0.275	0.006	456.06	2.16	6.99	0.15	-465
-466	18 1/2	1/4	18.455	0.085	0.275	0.006	468.76	2.16	6.99	0.15	-466
-467	19	1/4	18.955	0.090	0.275	0.006	481.46	2.29	6.99	0.15	-467
-468	19 1/2	1/4	19.455	0.090	0.275	0.006	494.16	2.29	6.99	0.15	-468
-469	20	1/4	19.955	0.095	0.275	0.006	506.86	2.41	6.99	0.15	-469
-470	21	1/4	20.955	0.095	0.275	0.006	532.26	2.41	6.99	0.15	-470
-471	22	1/4	21.955	0.100	0.275	0.006	557.66	2.54	6.99	0.15	-471
-472	23	1/4	22.940	0.105	0.275	0.006	582.68	2.67	6.99	0.15	-472
-473	24	1/4	23.940	0.110	0.275	0.006	608.08	2.79	6.99	0.15	-473
-474	25	1/4	24.940	0.115	0.275	0.006	633.48	2.92	6.99	0.15	-474
-475	26	1/4	25.940	0.120	0.275	0.006	658.88	3.05	6.99	0.15	-475

AS568 DIMENSIONS

AS568 is the Aerospace Size Standard for O-rings from the Society of Automotive Engineers. Simrit manufactures and supplies the complete range of standard AS568 sizes in a wide range of elastomeric O-ring materials. The following sizes are grouped by cross-section and listed numerically by inside diameter.

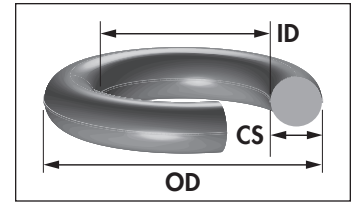

AS568 SIZE	Nominal (refer.)		Measurements in inches				Measurements in millimeters				AS568 SIZE
	ID	CS	ID	±	CS	±	ID	±	CS	±	
-901	3/32		0.185	0.005	0.056	0.003	4.70	0.13	1.42	0.08	-901
-902	1/8		0.239	0.005	0.064	0.003	6.07	0.13	1.63	0.08	-902
-903	3/16		0.301	0.005	0.064	0.003	7.65	0.13	1.63	0.08	-903
-904	1/4		0.351	0.005	0.072	0.003	8.92	0.13	1.83	0.08	-904
-905	5/16		0.414	0.005	0.072	0.003	10.52	0.13	1.83	0.08	-905
-906	3/8		0.468	0.005	0.078	0.003	11.89	0.13	1.98	0.08	-906
-907	7/16		0.530	0.007	0.082	0.003	13.46	0.18	2.08	0.08	-907
-908	1/2		0.644	0.009	0.087	0.003	16.36	0.23	2.21	0.08	-908
-909	9/16		0.706	0.009	0.097	0.003	17.93	0.23	2.46	0.08	-909
-910	5/8		0.755	0.009	0.097	0.003	19.18	0.23	2.46	0.08	-910
-911	11/16		0.863	0.009	0.116	0.004	21.92	0.23	2.95	0.10	-911
-912	3/4		0.924	0.009	0.116	0.004	23.47	0.23	2.95	0.10	-912
-913	13/16		0.986	0.010	0.116	0.004	25.04	0.25	2.95	0.10	-913
-914	7/8		1.047	0.010	0.116	0.004	26.59	0.25	2.95	0.10	-914
-916	1		1.171	0.010	0.116	0.004	29.74	0.25	2.95	0.10	-916
-918	1 1/8		1.355	0.012	0.116	0.004	34.42	0.30	2.95	0.10	-918
-920	1 1/4		1.475	0.014	0.118	0.004	37.47	0.36	3.00	0.10	-920
-924	1 1/2		1.720	0.014	0.118	0.004	43.69	0.36	3.00	0.10	-924
-928	1 3/4		2.090	0.018	0.118	0.004	53.09	0.46	3.00	0.10	-928
-932	2		2.337	0.018	0.118	0.004	59.36	0.46	3.00	0.10	-932

Freudenberg–NOK Sealing Technologies

Marketing Communications
47690 East Anchor Court
Plymouth, MI 48170
USA

Service Contact:

Phone: +1 734 451 0020
email: information.us@fnst.com

www.fnst.com